

# 5.1 Exploded View Illustration

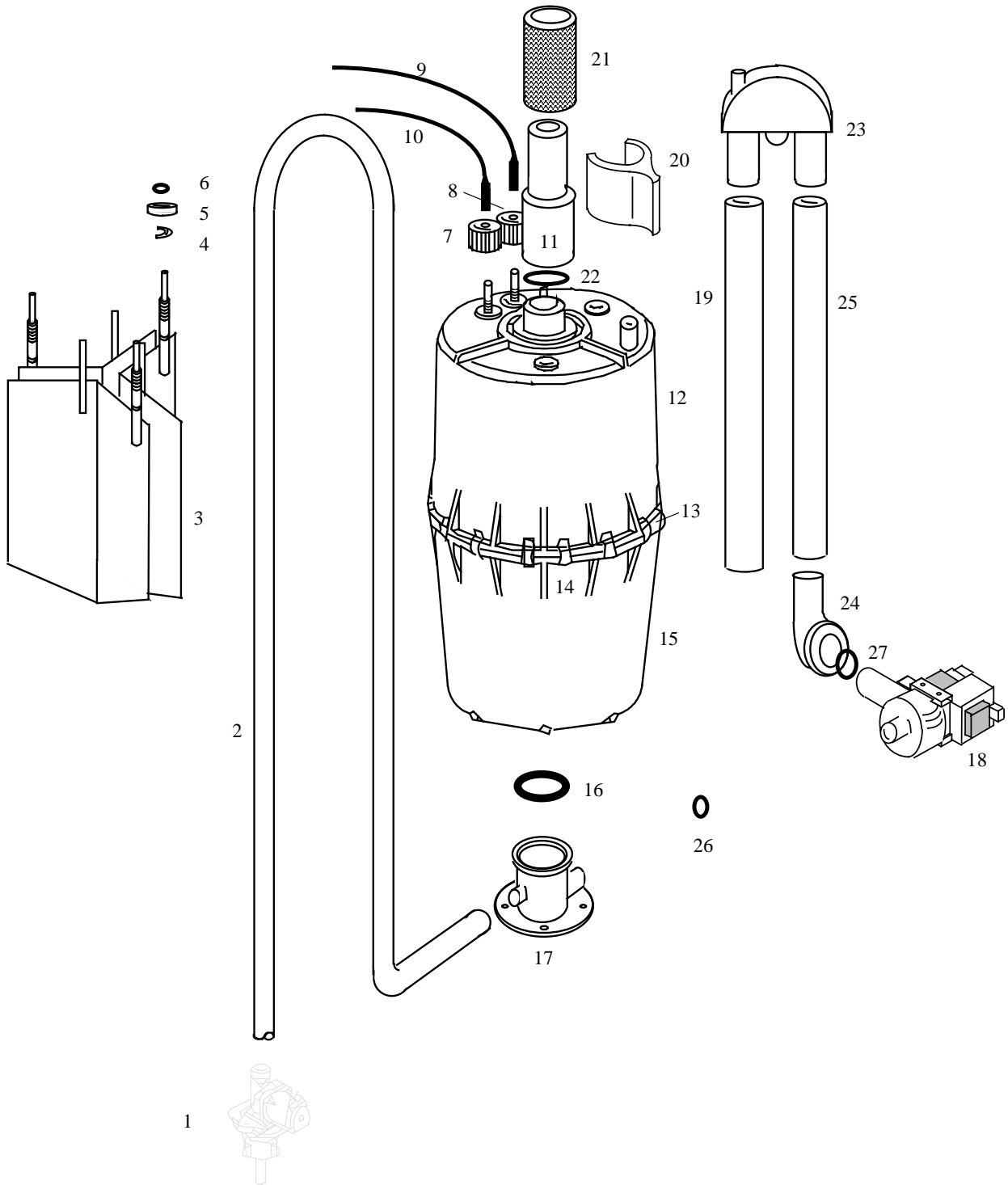

*	DBE						Article No.	Description
	2	4	8	17	30	45		
								<b>Bracket</b>
	1	1	1		1	1	E-2101014	Steam section retaining bracket
							E-2107012	Steam section retaining bracket
						1	E-2107016	Steam section retaining bracket
								<b>Steam Generation</b>
	1						B-3204049	Steam cylinder CY2 compl. with electrodes and Hand nuts
		1					B-3216067	Steam cylinder CY4 compl. with electrodes and Hand nuts
			1				B-3204031	Steam cylinder CY8 compl. with electrodes and Hand nuts
				1			B-2204101	Steam cylinder CY17 compl. with electrodes and Hand nuts
					1		B-2204111	Steam cylinder CY17 DN40 compl. with electrodes and Hand nuts
						1	B-2204105	Steam cylinder CY30 compl. with electrodes and Hand nuts
12	1						E-3216006	Top part of steam cylinder CY2 DN 20/9, empty
12		1					E-3216043	Top part of steam cylinder CY4 DN 20/9, empty
12			1				E-3226005	Top part of steam cylinder CY8 DN 25/12, empty
12				1			E-2206068	Top part of steam cylinder CY17 DN 25/12, empty
12					1		E-2206082	Top part of steam cylinder CY17 DN 40/12, empty
12						1	E-2206069	Top part of steam cylinder CY30 DN 40/12, empty
15	1		1				B-3216007	Lower part of steam cylinder compl. with strainer
15		1					B-3216044	Lower part of steam cylinder compl. with strainer
15				1	1		B-2206046	Lower part of steam cylinder compl. with strainer
15						1	B-2206071	Lower part of steam cylinder compl. with strainer
13	1		1				E-3216010	O-ring seal for cylinder flange, transparent cylinder
13		1					E-3216046	O-ring seal for cylinder flange, transparent cylinder
13				1	1		E-2206050	O-ring seal for cylinder flange, transparent cylinder
13						1	E-2206051	O-ring seal for cylinder flange, transparent cylinder
16	1	1	1				E-3216011	O-ring seal for cylinder base
16				1	1	1	E-2204022	O-ring seal for cylinder base
3	1						B-3204041	Electrodes compl. without Hand nuts, set=2pc. for CY2
3		1					B-3216061	Electrodes compl. without Hand nuts, set=3pc. for CY4
3			1				B-3204019	Electrodes compl. without Hand nuts, set=3pc. for CY8
3				1			B-2204081	Electrodes compl. without Hand nuts, set=3pc. for CY17
3					1	1	B-2204083	Electrodes compl. without Hand nuts, set=6pc. for CY17/30 DN40
	1						B-3204047	Sensor electrode compl. without hand nut
		1					B-3204037	Sensor electrode compl. without hand nut
			1				B-3204027	Sensor electrode compl. without hand nut
				1	1	1	B-2204075	Sensor electrode compl. without hand nut
9	1	1	1	1	1	1	E-3216025	Plug-in contact with insulating hose for sensorelectrode
10	2	3	3				E-3216024	Plug-in contact with insulating hose for steam generating electrodes
10				3	6	6	E-2206059	Plug-in contact with insulating hose for steam generating electrodes
14	12	12	12	18	18	24	E-3216022	Clamp for flange of transparent cylinder
	1	1	1	1	1	1	E-2204023	Strainer in cylinder
17	1	1	1				E-3220000	Cylinder base DN 20/12
17				1	1	1	E-2206086	Cylinder base DN 40/15/12
	1	1	1	1	1	1	B-3216023	Mounting set for cylinder base
	1	1					E-3216021	Condensate plug DN 9
			1	1	1	1	E-2204035	Condensate plug DN 12
11	1	1					E-3221000	Adapter DN20/25 for steam hose DN25
20	1	1					E-3221004	Clip for adapter DN25
22	1	1					E-3216011	O-ring for adapter DN20/25

\* see diagram 5.1

*	DBE						Article No.	Description
	2	4	8	17	30	45		
								<b>Water feed</b>
2	2	2	2	2	2	2	E-2304015	Hose clamp d=12 mm for waterinlet hose
1	0,60	0,60	0,60	0,60	0,60	0,60	E-2604014	Connecting hose, solenoid valve - cylinder base
1		1					B-2304081	Solenoid valve, servo controlled, straight type, 0,2 - 10 bar, 1,2 l/min
1	1		1				B-2304083	Solenoid valve, servo controlled, straight type, 0,2 - 10 bar, 2,5 l/min
1				1	1	1	B-2304085	Solenoid valve, servo controlled, straight type, 0,2 - 10 bar, 3,0 l/min
	1	1	1	1	1	1	B-2304040	Mounting set for solenoid valve
	1	1	1	1	1	1	E-2304036	Rubber seal solenoid valve - cabinet
	1	1	1	1	1	1	B-2304024	Threaded inlet fitting for solenoid valve, pipe=10mm, complete with
								<b>Water drain</b>
	1	1					B-3401001	Water-drain-hose-system (Pos.19,23,24,25,27)
			1				B-3401003	Water-drain-hose-system (Pos.19,23,24,25,27)
				1	1		B-3401005	Water-drain-hose-system (Pos.19,23,24,25,27)
						1	B-3401007	Water-drain-hose-system (Pos.19,23,24,25,27)
27	1	1	1	1	1	1	E-3220005	O-ring for adapter pump - drain hose
26	1	1	1	1	1	1	E-3220005	O-ring cylinder base - pump
18	1	1	1	1	1	1	B-2404021	Drain pump without mounting set
	1	1	1	1	1	1	E-2404008	Drain pump housing
	1	1	1	1	1	1	E-2404006	O-ring seal for drain pump
	1	1	1	1	1	1	B-2424014	Mounting set for drain pump
	0,3	0,3	0,4	0,6	0,6	0,6	E-2604010	Hose EPDM (for manual draining)
	1	1	1	1	1	1	E-2604062	Stopper for hose E-2604010
								<b>L-Electronic</b>
	1	1	1	1	1	1	B-3504071	L-Electronic pcb compl. without mounting holder
	1	1	1	1	1	1	E-2525121	cover for electronic pcb
	1	1	1	1	1	1	B-2525122	mounting set for cover
	1	1	1	1	1	1	E-2525152	Terminal 2-pole
	1	1	1	1	1	1	E-2525154	Terminal 3-pole
	1	1	1	1	1	1	E-2525156	Terminal 4-pole
	1	1	1	1	1	1	E-2525158	Terminal 6-pole
	x	x	x	x	x	x	B-2502412	Control switch, double pole, middle position "0"
								<b>EMP-Electronic</b>
	1	1	1	1	1	1	E-2525170	EMP-Electronic without mounting holder
	1	1	1	1	1	1	B-2120853	Mounting plate for electronics with foil
	1	1	1	1	1	1	E-2525116	Terminal 4-pole
	1	1	1	1	1	1	E-2525118	Terminal 6-pole
	1	1	1	1	1	1	E-2525120	Terminal 9-pole
	x	x	x	x	x	x	E-2502414	Control switch, double pole, black
								<b>ST-electronic</b>
	1	1	1				E-3524100	ST-electronic pcb
	1	1	1				B-2120851	Mounting plate for electronics with foil

\* see diagram 5.1

*	DBE						Article No.	Description
	2	4	8	17	30	45		
								<b>Accessories</b>
	x	x	x	x			E-2604012	Steam hose DN25, per m
					x	x	E-2604013	Steam hose DN 40, per m
	x	x	x	x	x	x	E-2604014	Condensate hose DN 12, per m
	x	x	x	x			E-2404004	Steam hose clamp DN 25
					x	x	E-2604016	Steam hose clamp DN 40
	x	x	x	x	x	x	E-2304015	Condensate hose clamp
	x	x	x	x			B-2604026	Steam solenoid valve 0-0,4 bar, compl. for steam hose DN 25
					x	x	B-2604040	Steam solenoid valve 0-0.4 bar, compl. for steam hose DN 40
	x	x	x	x			E-2604019	Connectors for steam distribution T-piece DN 25
					x	x	E-2604020	Connectors for steam distribution T-piece DN 40
	x	x	x	x	x	x	E-2604021	Connectors for condensate T-piece DN 12
			x				B-2208005	Cylinder Star
				x			B-2208007	Cylinder Star
					x		B-2208013	Cylinder Star
						x	B-2208009	Cylinder Star
	x	x	x	x			E-2604030	Elbows 90° DN 25, stainless steel
					x	x	E-2604036	Elbows 90° DN 40, stainless steel
		x					B-3304061	Super Flush
			x				B-3304063	Super Flush
				x	x	x	B-2304065	Super Flush

\* see diagram 5.1