

5.1 DB-MP

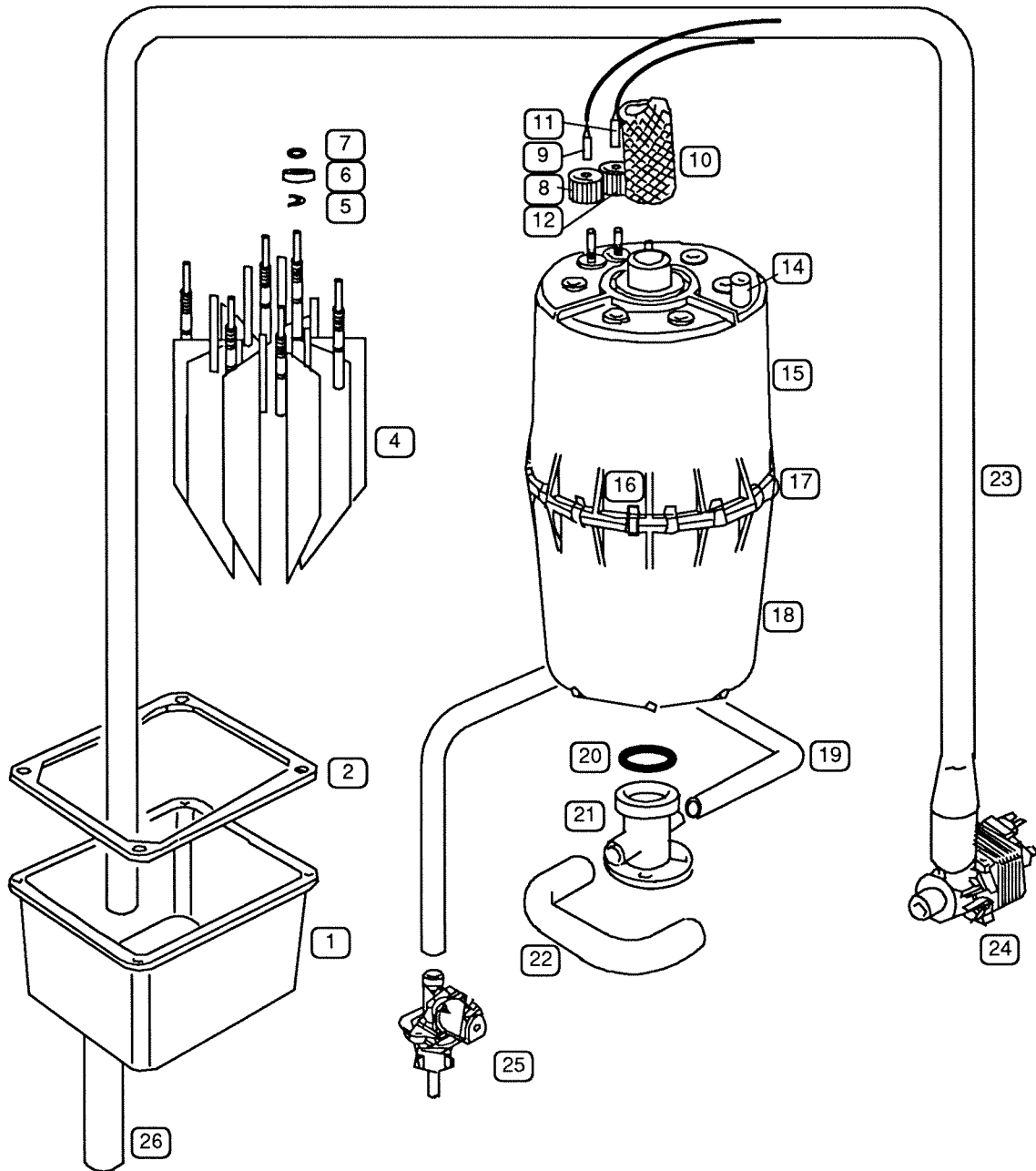

*	DB						Art. Nr.	Description
	4-8	10-17	23-30	45	60	90		
							Cabinet	
	1		1				B-3120403 Cabinet, excl. electric blind, beige, green, empty	
		1	1				B-2120503 Cabinet, excl. electric blind, beige, green, empty	
				1			B-2121002 Cabinet, excl. electric blind, beige, green, empty	
					1		B-2120802 Cabinet, excl. electric blind, beige, green, empty	
						1	B-2121102 Cabinet, excl. electric blind, beige, green, empty	
	1						E-3120419 Front panel for steam section	
		1	1				E-2120519 Front panel for steam section	
				1			E-2121019 Front panel for steam section	
					1		E-2120819 Front panel for steam section	
						1	E-2121119 Front panel for steam section	
	1						E-3120420 Front panel for electric section, excl. electric blind	
		1	1				E-2120520 Front panel for electric section, excl. electric blind	
				1			E-2121020 Front panel for electric section, excl. electric blind	
					1		E-2120820 Front panel for electric section, excl. electric blind	
						1	E-2121120 Front panel for electric section, excl. electric blind	
	1	1	1	1	2	2	E-2124014 Safety lock for electric panel DB4-90 and steam panel DB60,90	
	1	1	1	1			E-2124016 Safety lock for steam panel DB4-45	
	2	2	2	2	2	2	E-2124015 Key for safety lock (per set = 2 pc.)	
	1	1	1	1	2	2	E-2120102 Grip for electric panel DB4-90 / steam panel DB60,90, green, without lock	
	1	1	1	1			E-2120101 Grip for steam panel DB4-45, green, without lock	
	1						B-3126010 Complete set of cable entry fittings for connecting cable	
		1	1				B-2125016 Complete set of cable entry fittings for connecting cable	
				1			B-2127014 Complete set of cable entry fittings for connecting cable	
					1		B-2123017 Complete set of cable entry fittings for connecting cable	
						1	B-2127024 Complete set of cable entry fittings for connecting cable	
	1						E-3120406 Blind electric panel, L-electronic	
		1	1				E-2120506 Blind electric panel, L-electronic	
				1			E-2121006 Blind electric panel, L-electronic	
	1						E-3120404 Blind electric panel, EM-electronic	
		1	1				E-2120504 Blind electric panel, EM-electronic	
				1			E-2121004 Blind electric panel, EM-electronic	
					1		E-2120804 Blind electric panel, EM-electronic	
						1	E-2121104 Blind electric panel, EM-electronic	
	1						E-3120405 Blind electric panel, MP-electronic	
		1	1				E-2120505 Blind electric panel, MP-electronic	
				1			E-2121005 Blind electric panel, MP-electronic	
					1		E-2120805 Blind electric panel, MP-electronic	
						1	E-2121105 Blind electric panel, MP-electronic	
					1		E-2120810 Blind steam panel	
						1	E-2121110 Blind steam panel	
	3	3	3	3	6	6	E-2120001 Screw M4 for mounting grip E-2120102	
	5	5	5	5	10	10	E-2505123 Plastic cap nut M3 for mounting electric and steam blind	
	1	1	1	2	1	2	E-2120002 Blind plug for hole in the steam part bottom	
							Steam Generation	
	1						B-3204031 Steam cylinder CY 8 transp. compl. with electrodes, ready for installation	
		1					B-2204101 Steam cylinder CY17 transp. compl. with electrodes, ready for installation	
			1		2		B-2204105 Steam cylinder CY30 transp. compl. with electrodes, ready for installation	
				1		2	B-2204109 Steam cylinder CY45 transp. compl. with electrodes, ready for installation	
15	1						E-3226005 Top part of steam cylinder, DN 25/12, empty	
15		1					E-2206068 Top part of steam cylinder, DN 25/12, empty	
15			1			2	E-2206069 Top part of steam cylinder, DN 40/12, empty	

*	DB						Art. Nr.	Description
	4-8	10-17	23-30	45	60	90		
15				1		2	E-2207001	Top part of steam cylinder 2xDN 40/12, empty
18	1						B-3216007	Lower part of steam cylinder, compl. with strainer
18		1					B-2206046	Lower part of steam cylinder, compl. with strainer
18			1		2		B-2206071	Lower part of steam cylinder, compl. with strainer
18				1		2	B-2207002	Lower part of steam cylinder, compl. with strainer
	1						B-3204025	Top part of steam cylinder, compl. with electrodes for CY8
		1					B-2204095	Top part of steam cylinder, compl. with electrodes for CY17
			1		2		B-2204099	Top part of steam cylinder, compl. with electrodes for CY30
				1		2	B-2204079	Top part of steam cylinder, compl. with electrodes for CY45
17	1						E-3216010	O-ring seal for cylinder flange, transparent cylinder
17		1					E-2206050	O-ring seal for cylinder flange, transparent cylinder
17			1		2		E-2206051	O-ring seal for cylinder flange, transparent cylinder
17				1		2	E-2207011	O-ring seal for cylinder flange, transparent cylinder
20	1						E-3216011	O-ring seal for cylinder base
20		1	1	1	2	2	E-2204022	O-ring seal for cylinder base
4	1						B-3204021	Electrodes, compl. without Hand nuts for CY8, Set=3pc.
4		1					B-2204087	Electrodes, compl. without Hand nuts for CY17, Set=3pc.
4			1		2		B-2204089	Electrodes, compl. without Hand nuts for CY30, Set=6pc.
4				1		2	B-2204091	Electrodes, compl. without Hand nuts for CY45, Set=6pc.
	1						B-3204029	Sensor electrode, compl. without Hand nut, max. limitation
		1	1	1	2	2	B-2204073	Sensor electrode, compl. without Hand nut, max. limitation
6	3						E-3204010	Retainer for O-ring, electrode
6		3	6		12		E-2204062	Retainer for O-ring, electrode
6				6		12	E-2204064	Retainer for O-ring, electrode
5	3						E-3204022	Safety washer RA5.0 for electrode
5		3	6		12		E-2204086	Safety washer RA6.0 for electrode
5				6		12	E-2204088	Safety washer RA8.0 for electrode
7	3						E-3216018	O-ring electrode, 5mm
7		3	6		12		E-2204020	O-ring electrode, 8mm
7				6		12	E-2207012	O-ring electrode, 10mm
	1	1	1	1	2	2	E-3204010	Retainer for O-ring, sensor electrode
	1	1	1	1	2	2	E-3204022	Safety washer RA5.0 for sensor electrode
	1	1	1	1	2	2	E-3216018	O-ring sensor electrode 5mm
8	1						E-3204014	Hand nut for electrode fastening, M6, colour: red
8	1						E-3204016	Hand nut for electrode fastening, M6, colour: black
8	1						E-3204018	Hand nut for electrode fastening, M6, colour: grey
8		1	2		4		E-2204068	Hand nut for electrode fastening, M8, colour: red
8		1	2		4		E-2204070	Hand nut for electrode fastening, M8, colour: black
8		1	2		4		E-2204072	Hand nut for electrode fastening, M8, colour: grey
8				2		4	E-2204074	Hand nut for electrode fastening, M10, colour: red
8				2		4	E-2204076	Hand nut for electrode fastening, M10, colour: black
8				2		4	E-2204078	Hand nut for electrode fastening, M10, colour: grey
12	1	1	1	1	2	2	E-3204018	Hand nut for sensor electrode fastening, M6, colour: grey
11	1	1	1	1	2	2	E-3216025	Plug-in contact with insulating hose for sensor electrode
9	3						E-3216024	Plug-in contact with insulating hose for electrode
9		3	6		12		E-2206059	Plug-in contact with insulating hose for electrode
9				6		12	E-2207016	Plug-in contact with insulating hose for electrode
16	12	18	24	24	48	48	E-3216022	Clamp for flange of transparent cylinder
	1	1	1	1	2	2	E-2204023	Drain filter
21	1						E-3216050	Base for steam cylinder
21		1	1	1	2	2	E-2206052	Base for steam cylinder
	2	2	2	2	4	4	E-2204034	Plastic cap-nut M5 for mounting cylinder base
14	1	1	1	1	2	2	E-2204035	Condensate plug

* Pos.-Nr. diagram 5.1

*	DB						Art. Nr.	Description
	4-8	10-17	23-30	45	60	90		
Water feed								
19	2	2	2	2	4	4	E-2304015 Clamp for connecting hose solenoid valve - cylinder base, d= 12mm	
19	1						B-3326002 Connecting hose, solenoid valve - cylinder base, l=1000mm	
19		1	1		2		B-2325013 Connecting hose, solenoid valve - cylinder base, l=1500mm	
19				1		2	B-2327000 Connecting hose, solenoid valve - cylinder base, l=1950mm	
25	1						B-2304017 Solenoid valve, servo controlled, straight type, 0,2-10bar, 2,5l/min.	
25		1	1	1	2	2	B-2307001 Solenoid valve, servo controlled, straight type, 0,2-10bar, 3,5l/min.	
	1	1	1	1	2	2	E-2304029 Fine filter in the inlet fitting of solenoid valve	
	1						E-3320400 Flow rate controller 2.5l/min.	
		1	1	1	2	2	E-2321100 Flow rate controller 3.5l/min.	
	1	1	1	1	2	2	E-2304036 Rubber seal solenoid valve - cabinet	
	1	1	1	1	2	2	E-2304031 Servo controlled membrane for solenoid valve	
	1	1	1	1	2	2	B-2304038 Valve piston with springs	
	1	1	1	1	2	2	B-2304039 Piston coating, valve cover, coil-spring	
	1	1	1	1	2	2	E-2304034 Solenoid valve coil with bayonet fitting, 230V/50-60Hz	
	1	1	1	1	2	2	B-2304024 Threaded inlet fitting for solenoid valve, pipe d=10mm,	
	1	1	1	1	2	2	B-2304030 Plastic union nut compl with sealing for solenoid valve	
Water Drain								
	1						E-3616006 Clamp for drain hose, from cylinder base to drain pump	
22	2	3	3	3	6	6	E-2404004 Clamp f. drain hose, from cyl. base to drain pump DB10-90/pump DB4-90	
22	1						E-2403995 Drain hose from base to drain pump	
22		1	1		2		E-2404002 Drain hose from base to drain pump	
22				1		2	E-2407001 Drain hose from base to drain pump	
24	1	1	1	1	2	2	B-2404005 Drain pump without mounting set	
	1	1	1	1	2	2	E-2404008 Cover for drain pump	
	1	1	1	1	2	2	E-2404009 Impeller for drain pump	
	1	1	1	1	2	2	E-2404006 O-Ring seal for drain pump	
	1	1	1	1	2	2	E-2404007 Shaft seal for drain pump	
	1	1	1	1	2	2	B-2424014 Mounting set for drain pump	
	1	1	1	1	2	2	E-3416003 Fastening clamp for drain hose	
	1	1	1	1			E-3416005 Fastening clamp for drain hose, for split models	
23	1						E-3426009 Pump drain hose DN15, L=900mm	
23		1	1		2		E-2424003 Pump drain hose DN15, L=1445mm	
23				1		2	E-2427000 Pump drain hose DN15, L=1670mm	
	2	2	2	2	4	4	E-2420427 Nut for mounting tundish	
	1	1	1	1	2	2	E-2404004 Clamp for tundish hose	
	1	1	1	1	2	2	E-2420425 Drain hose for tundish, DN1 inch, per m	
1+2	1	1	1	1	2	2	B-2420421 Tundish for drain water incl. sealing	
2	1	1	1	1	2	2	E-2420426 Sealing for tundish	
Electronic								
	1	1	1	1	2	2	B-2502400 Control switch, single pole, incl. protecting cap	
	1						E-2501005 Main contactor 16A, 230V	
		1					E-2501006 Main contactor 24A, 230V	
			1		2		E-2505007 Main contactor 40A, 230V	
				1		2	E-0505009 Main contactor 63A. 230V	
	1	1	1	1	2	2	E-2525151 Transformer 230V/9V, 15VA	
	1	1	1	1	2	2	E-2504039 Control fuse 5A, 5x20 mm	
	1						B-3520001 Connecting cable terminal block - main contactor, set=3pc	
		1					B-2524044 Connecting cable terminal block - main contactor, set=3pc	
			1		2		B-2524045 Connecting cable terminal block - main contactor, set=3pc	
				1		2	B-2527011 Connecting cable terminal block - main contactor, set=3pc	

*	DB						Art. Nr.	Description
	4-8	10-17	23-30	45	60	90		
1		1					B-3526013 Connecting cables for electrodes with plug-in contact, set=3pc	
			1		1		B-2524035 Connecting cables for electrodes with plug-in contact, set=3pc	
				1			B-2524036 Connecting cables for electrodes with plug-in contact, cylinder1, set=6pc	
					1		B-2524037 Connecting cables for electrodes with plug-in contact, cylinder2, set=6pc	
				1		1	B-2527009 Connecting cables for electrodes with plug-in contact, cylinder1, set=6pc	
						1	B-2527010 Connecting cables for electrodes with plug-in contact, cylinder2, set=6pc	
1							B-3520401 Main wire loom	
	1	1					B-2520501 Main wire loom	
				1			B-2521001 Main wire loom	
					1		B-2520801 Main wire loom	
						1	B-2521101 Main wire loom	
1	1	1	1	1	2	2	E-2525121 Cover for electronic pcb	
1	1	1	1	1	2	2	B-2525122 Mounting set for cover	
					1	1	E-2504008 Auxiliary relay 230V - 3-pole, plug-in type	
					1	1	E-2504023 Socket for auxiliary relay	
L-Electronic								
1	1	1	1				B-3524062 L-electronic pcb compl. with module holder	
1	1	1	1				E-3516010 Operation control lamp, "green", 230V	
1	1	1	1				E-3516011 LED "red" for cylinder max. level	
1							B-3524080 Terminal block complete for L-electronic	
	1						B-2524081 Terminal block complete for L-electronic	
		1					B-2524082 Terminal block complete for L-electronic	
			1				B-2524083 Terminal block complete for L-electronic	
1							B-3524001 Wire loom signal lamp control	
	1	1					B-2524002 Wire loom signal lamp control	
				1			B-2524003 Wire loom signal lamp control	
1	1	1	1				E-3524070 Signal output pcb for collective fault	
EM - electronic								
1	1	1	1	2	2		B-2525160 EM-electronic pcb compl. with module holder	
1	1	1	1	2	2		E-2525131 Display for EM-electronic	
1							B-3525080 Terminal block complete for EM-electronic	
	1						B-2525081 Terminal block complete for EM-electronic	
		1					B-2525082 Terminal block complete for EM-electronic	
			1				B-2525083 Terminal block complete for EM-electronic	
				1			B-2525084 Terminal block complete for EM-electronic	
					1		B-2525085 Terminal block complete for EM-electronic	
1	1	1		1			B-2525002 Wire loom prop. control for EM-electronic	
				1	1	2	B-2525003 Wire loom prop. control for EM-electronic	
	1	1	1				B-2525135 Bus cable EM - RO 0,3m	
1					2		B-2525136 Bus cable EM - RO 0,5m	
						2	B-2525137 Bus cable EM - RO 0,7m	
1	1	1	1	2	2		B-2525141 Ro signal output pcb complete with module holder	
1	1	1	1				B-0623023 Signal outputs "Operation" and "Collective fault"	
					1	1	B-0623037 Signal outputs "Operation" and "Collective fault"	
MP-electronic								
1	1	1	1	2	2		B-2522492 MT - pcb compl. with module holder	
1	1	1	1	2	2		E-2522494 MP-electronic/Display for MP-electronic	
1	1	1			2		B-3522451 Bus cable MP - MT 1,05m	
			1			2	B-2522453 Bus cable MP - MT 1,35m	
1							B-3522480 Terminal block complete for MP-electronic	
	1						B-2522481 Terminal block complete for MP-electronic	

*	DB						Art. Nr.	Description
	4-8	10-17	23-30	45	60	90		
			1				B-2522482	Terminal block complete for MP-electronic
				1			B-2522483	Terminal block complete for MP-electronic
					1		B-2522484	Terminal block complete for MP-electronic
						1	B-2522485	Terminal block complete for MP-electronic
	1	1	1		1		B-2522402	Wire loom prop. control for MP-electronic
				1	1	2	B-2522403	Wire loom prop. control for MP-electronic
	1	1	1		1		B-3522452	Bus cable MP - MT - RO 1,43m
				1	1	2	B-2522454	Bus cable MP - MT - RO 1,94m
	1	1	1	1	2	2	B-2525141	RO signal output pcb complete with module holder
Accessories								
	x	x					E-2604249	Steam distributor, DN 25, 240mm, holes evenly spaced
	x	x					E-2604251	Steam distributor, DN 25, 400mm, holes evenly spaced
	x	x					E-2404253	Steam distributor, DN 25, 700mm, holes evenly spaced
	x	x					E-2604255	Steam distributor, DN 25, 1000mm, holes evenly spaced
	x	x					E-2304256	Steam distributor, DN 25, 1300mm, holes evenly spaced
			x	x	x	x	E-2604400	Steam distributor, DN 40, 300mm, holes evenly spaced
			x	x	x	x	E-2604402	Steam distributor, DN 40, 500mm, holes evenly spaced
			x	x	x	x	B-3626403	Steam distributor, DN 40, 700mm, holes evenly spaced
			x	x	x	x	B-2624404	Steam distributor, DN 40, 900mm, holes evenly spaced
			x	x	x	x	B-2604406	Steam distributor, DN 40, 1300mm, holes evenly spaced
	x	x					E-2604012	Steam hose DN25, per m
			x	x	x	x	E-2604013	Steam hose DN 40, per m
	x	x	x	x	x	x	E-2604014	Condensate hose DN 12, per m
	x	x					E-2404004	Steam hose clamp DN 25
			x	x	x	x	E-2604016	Steam hose clamp DN 40
	x	x	x	x	x	x	E-2304015	Condensate hose clamp DN 12
	x	x					E-2604019	Connectors for steam distribution T-piece DN 25
			x	x	x	x	E-2604020	Connectors for steam distribution T-piece DN 40
	x	x	x	x	x	x	E-2604021	Connectors for condensate T-piece DN 12
	1						B-3626010	Mounting kit
		1	1				B-2624022	Mounting kit
				1			B-2624023	Mounting kit
					1		B-2624024	Mounting kit
	x	x					B-2604026	Steam solenoid valve 0-0,4 bar, compl. for steam hose DN 25
			x	x	x	x	B-2604040	Steam solenoid valve 0-0.4 bar, compl. for steam hose DN 40
							E-2604029	Hose adapter DN 25
	x	x					E-2604030	Elbows 90° DN 25, stainless steel
			x	x	x	x	E-2604034	Elbows 90° DN 40, plastic
			x	x	x	x	E-2604036	Elbows 90° DN 40, stainless steel
							E-2604031	Connector DN 40/25
	1						B-2208005	Cylinder star
		1					B-2208007	Cylinder star
			1		2		B-2208009	Cylinder star
				1		2	B-2208011	Cylinder star
	1						B-2304063	Super flush complete
		1	1	1	2	2	B-2304065	Super flush complete

* Pos.-Nr. diagram 5.1