

CompactLine Kit

Electrode Steam Humidifier



A Word about Water Quality

The mode of operation of all electrode steam humidifiers is based on the fact that water contains minerals and is therefore conductive.

- "normal" tap water is ideal.
- but what is "normal" tap water exactly?

Users of HygroMatik units in the most diverse areas consider their tap water "normal."

HygroMatik typically defines "normal" as feed water with a conductivity between 200 and 500 $\mu\text{S}/\text{cm}$ (microSiemens per centimeter) at 15° C.

Some areas, however, are supplied with tap water whose quality is outside the parameters specified by HygroMatik. If the HygroMatik steam humidifier's control is not adjusted correctly in these areas, the unit cannot perform optimally. For example, the electrodes could wear out particularly quickly or the steam production could be too low.

The operational parameters set by HygroMatik in the factory are intended for normal tap water. However, they can very easily be reprogrammed to fit the special requirements of a particular area. In addition, it is possible to install a plastic star in the cylinder in order to increase the life span of the electrodes or to provide a flushing mechanism to extend maintenance intervals.

Because of this you should monitor your new unit during initial operation. Make sure that it has been properly installed and is operating to your satisfaction.

Consult your HygroMatik specialists. We will test the quality of your water and advise you on installation and initial operation. Your HygroMatik steam humidifier will be carefully adapted to your particular application.

© Copyright HygroMatik GmbH; CLK.21.06.2013.EN

Information in this manual is subject to change or alteration without prior notice.

Current version of this manual can be found at: www.hygromatik.co.uk



Warning, Hazardous Voltage: All work to be performed by trained personnel only. All electrical installation and servicing of the electrical components of this unit to be performed by qualified electricians only. Disconnect power supply before installation and servicing!

1. Introduction	5
1.1 Directions for Use	5
1.2 Typographic Distinctions	6
1.3 Documentation	7
2. Safety Notes	8
2.1 Overview	8
2.2 Guidelines for Safe Operation	8
2.3 Disposal after Dismantling	9
3. Transport	10
3.1 Overview	10
3.2 Carton outer Size and Weight	10
3.3 Packing	10
3.4 Interim Storage	10
3.5 Check for Complete and Correct Delivery of Goods	10
4. Operation and Installation	11
4.1 Mode of Operation	11
4.2 Installation and Operation	11
5. Installation	14
5.1 Steam Humidifier Operating Environment	14
5.1.1 Fitting	15
5.1.2 Equipment Dimensions CompactLine Kit	16
5.2 Fan Unit (optional)	17
5.2.1 Fan Unit Type VG	17
5.3 Absorption Distance BN	18
5.3.1 Determining the Absorption Distance	18
5.3.2 Absorption Distance Nomogram	20
5.4 Steam Manifold	21
5.4.1 Notes on Installation	21
5.5 Steam Line	25
5.6 Cover Plate	26
5.7 Drill Pattern	27
5.7.1 Drill Pattern DN25 (not to scale)	27
5.7.2 Drill Pattern DN40 (not to scale)	28
5.8 Condensate Hose	29
5.9 Types of Installation	29
5.10 Steam Solenoid Valves	32
5.11 Unit Installation Check	32
6. Water Installation	33
6.1 Operation with Softened Water	33
6.2 Water Supply	34
6.3 Water discharge	35
6.4 Water Installation Check	36
7. Electrical Connection	37

7.1 Electrical Installation	37
7.2 Safety Interlock	40
7.3 Wiring Diagram	40
7.4 Electrical Installation Checklist	40
8. Maintenance	41
8.1 Maintenance Work	42
8.1.1 Cleaning the Steam Cylinder	43
8.1.2 Electrode Wear	45
8.2 Replacing Electrodes	46
8.3 Cleaning the Blow- Down Pump	48
8.4 Cleaning the Water Inlet Solenoid Valve	49
8.5 Chekking Cable Connections and Electrode Cables	50
8.6 Checking Operation	51
8.7 Dismantling	51
9. Spare Parts	52
10. Fax Form - Order for spare parts	55
11. Exploded View	56
12. Technical Specification	57

1. Introduction

Dear Customer,

Thank you for choosing a steam humidifier.

HygroMatik steam humidifiers represent the latest in humidification technology.

They will impress you with their safety, ease of use and economical operation.

In order to operate your HygroMatik steam humidifier safely, properly and efficiently, please read these operating instructions.

Employ your steam humidifier only in sound condition and as directed. Consider potential hazards and safety issues and follow all the recommendations in these instructions.

If you have additional questions, please contact us:

Tel.: +49-(0)4193 / 895-0 (Main Number)

Tel.: +49-(0)4193 / 895-293 (Technical Support Hotline)

Fax: +49-(0)4193 / 895-33

e-mail: hot1@HygroMatik.de

For all technical questions or spare parts orders, please be prepared to provide unit type and serial number (see name plate on the unit).

1.1 Directions for Use

The HygroMatik steam humidifier is intended for steam production.

Proper usage also entails following HygroMatik's instructions for installation, dismantling, reassembly, initial operation and operation and maintenance, as well as disposal procedures.

Only qualified, authorized personnel may operate or service the unit. Workers who transport or service the unit must have read and understood the relevant sections of the operating instructions, especially the section "Safety Notes." In addition, staff must receive safety training about potential hazards from the operator. Place a copy of the operating instructions at the location where the unit is operated.

Use feed water with a conductivity between 125 and 1250 $\mu\text{S}/\text{cm}$ only

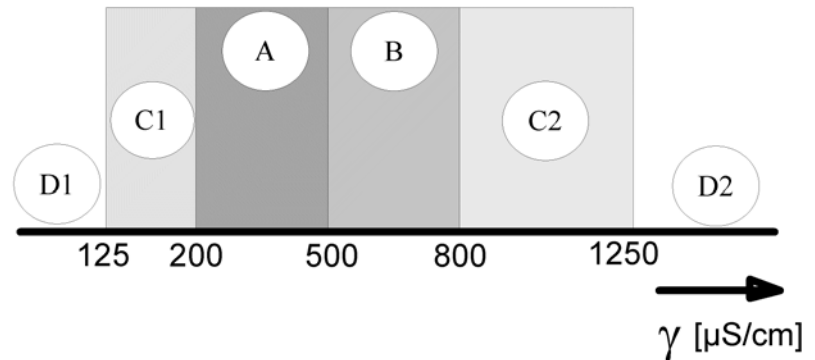

D1: Lower threshold

C1: Range of reduced conductivity (adjustments recommended)

A: Normal tap water

B: Range of heightened conductivity

C2: Range of high conductivity (adjustments recommended)

D2: Upper threshold



Warning: HygroMatik steam humidifiers emit steam with a temperature of 100° C. The steam may not be inhaled directly.

The HygroMatik Steam Humidifier is not designed for outdoor fitting

1.2 Typographic Distinctions

- preceded by a bullet: general specifications.
- » preceded by an arrow: Procedures for servicing or maintenance which should or must be performed in the indicated order.
- ☑ Installation step which must be checked off.
- italics* Terms used with graphics or drawings..

1.3 Documentation

Retention

Please retain these operating instructions in a secure, always accessible location. If the product is resold, turn the documentation over to the new operator. If the documentation is lost, please contact HygroMatik.

Versions in Other Languages

These operating instructions are available in several languages. If interested, please contact HygroMatik or your HygroMatik dealer.

2. Safety Notes

2.1 Overview

These safety notes are required by law. They promote workplace safety and accident prevention.

Warnings and Safety Symbols

The safety symbols below identify sections containing warnings about hazards or potential dangers. Please familiarize yourself with these symbols.



Warning: Failure to observe this warning may result in serious injury or death and/or damage to the unit.



Danger, Hazardous Voltage: Hazardous electrical current! Failure to observe this warning may result in injury or even serious injury or death.



Warning: Failure to follow these instructions may result in damage to the unit due to electrostatic discharge. The electronic components of the humidifier control are very sensitive to electrostatic discharges. In order to safeguard these components during installation and servicing, steps must be taken to protect against ESD.



Reminder: Materials and consumables must be handled and/or disposed of as required by law.



Note: Appears before explanations or cross-references which refer to other sections of the operating instructions.

2.2 Guidelines for Safe Operation

Overview

Obey all safety notes and warnings present on the unit. In case of a malfunction, switch off the unit immediately and prevent a restart. Repair malfunctions promptly. After any repair work, have qualified personnel check the safe operation of the unit.

Use original spare parts only. Additional national safety regulations also fully apply to the operation of this unit.

This unit is not designed for the use by persons (also children) with limited physical, sensory and mental abilities - or without knowledge and experience. Unless they are supervised or trained by a person, who is responsible for their safety.

Supervise children in order to ensure that they will not play with the unit.

The unit is only allowed to work with connected steam hose that safely leads the steam.

Accident Prevention Regulations



Attention: In the event of leaky or faulty components uncontrolled hot steam may flow.

HygroMatik steam humidifiers are IP20-protected. Make sure that the unit is protected from drips in its installed location.

Installing a humidifier in a room without water discharge requires safety devices to protect against water leakages.

Accident Prevention Regulations



Comply with the Accident Prevention Regulation Electrical Systems and Equipment to prevent injury to yourself and others.

Operation of the Unit:

Do not perform any work which compromises the safety of the unit. Regularly check that all safety and monitoring devices are functioning normally. Do not remove or disable safety devices.

Installation, Dismantling, Maintenance and Repair of the Unit:

Disconnect unit components from power supply prior to maintenance or repair work.

Attaching or installing **additional components** is permitted only with the **written consent** of the manufacturer.

Electrical



Work on the electrical system must be performed by qualified personnel.

Disconnect unit components from power supply prior to work.

It is not allowed to connect the unit to DC voltage supply.

In case of a malfunction in the electrical power supply, switch off the unit immediately. Use only original fuses with the appropriate amperage rating. Regularly check the unit's electrical equipment. Promptly repair any damage, such as loose connections, burned wiring or defective electrical insulation. After proper electrical installation or repair, test all safety mechanisms (such as grounding resistance).

2.3 Disposal after Dismantling



Note: The operator is responsible for the disposal of unit components as required by law.

3. Transport

3.1 Overview



Note: Proceed carefully when transporting the steam humidifier in order to prevent damage due to stress or careless loading and unloading.

3.2 Carton outer Size and Weight

Type*	Height [cm]	Width [cm]	Depth [cm]	Weight [kg]
C01Kit	49	20	29	4
C02Kit - C10Kit	49	20	29	8
C17Kit - C30Kit	66	50	66	12
C45Kit	72	40	40	15
Electronic	16,5	12	9	1

3.3 Packing



Note: Notice the symbols affixed to the packing box.

3.4 Interim Storage

Store the unit in a dry place and protect from frost.

3.5 Check for Complete and Correct Delivery of Goods

Upon receipt of the unit, confirm that:

- the type and serial number on the name plate match those specified in the order and delivery documents and
- the equipment is complete and all parts are in perfect condition



Note: In case of damage during shipment or missing parts, immediately notify the carrier or supplier in writing.

Time limits for filing freight claims with shipping companies are*:

Shipping Companies	After Receipt of Goods
Mail	no later than 24 hours
Rail	no later than 7 days
Truck and Rail Carriers	no later than 4 days
Parcel Service	immediately

* Time limits for some services subject to change.

4. Operation and Installation

4.1 Mode of Operation

The HygroMatik steam humidifier utilizes the conductivity normally present in tap water for steam production. Electrodes inside an enclosed steam cylinder are immersed directly into the tap water. They are connected to the alternating current.

The conductivity of the water generates an electric current between the electrodes. In this way, the electric power supplied is converted directly into heat without energy loss.

The amperage is a function of the available voltage, the immersed electrode surface area, the average distance between the electrodes and the water conductivity. The steam output of the humidifier is determined by electric power usage, which is regulated by increasing or decreasing the immersed surface area of the electrodes.

Concurrently, a self-regulating control keeps conductivity within a specified range.

The steam produced has a temperature of about 100°C with minimal excess pressure ("pressureless steam"). It is largely free of minerals and germ-free. Mineral deposits typically remain behind in the cylinder.

4.2 Installation and Operation

By pressing the control switch („Pos. I”) the humidifier is turned on. When the controller specifies an increase in humidity, the main contactor is switched on and the electrodes (48) are supplied with power. The water inlet solenoid valve (25) feeds water into the steam cylinder (16+19).

As soon as the electrodes are immersed, the current begins to flow. The water is now heated. When the pre-selected output is reached, the control turns off the solenoid valve and interrupts the water supply.

After a short heating up period, the water between the electrodes begins to boil and vaporize. The vaporization lowers the water level in the steam cylinder, reducing the output provided. The inlet solenoid valve, equipped with a fine mesh filter, intermittently admits fresh water.

Humidifier power usage is continuously monitored. With a cold start-up, the nominal current increases to 125% in order to achieve quick-start output parameters. This activates the electronic overflow limiter which causes a partial draining of the cylinder. This reduces the immersed surface area of the electrodes, lowering power usage.

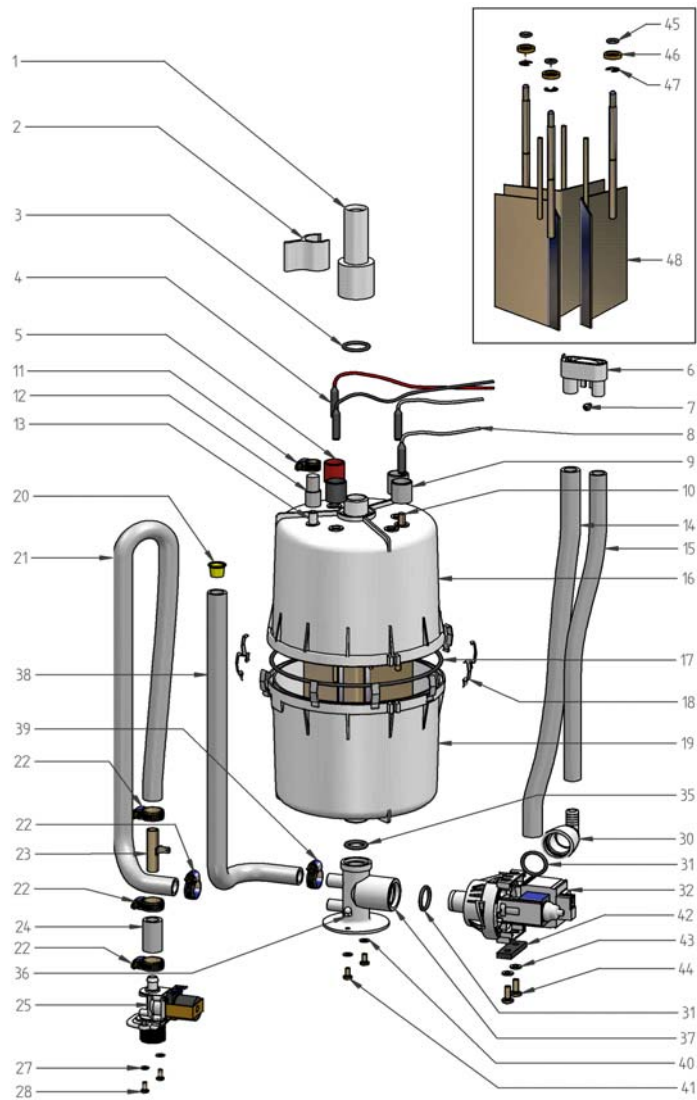

Please also see Section „Exploded View“.

Location	Designation
1	adapter
6	vent pipe
10	max. water level sensor electrode
14	water drain, discharge
16	top part of steam cylinder
17	o-ring cylinder flange
18	cylinder flange and o-ring
19	lower part of cylinder
25	solenoid valve water inlet
32	blow-down pump
35	o-ring
37	cylinder base
48	electrodes

The concentration of dissolved salts increases over time, which can lead to a rise in the conductivity of the water. If this continues, conductivity may increase until a short circuit occurs. This could damage the unit, but in any case would significantly reduce the life span of the electrodes.

For this reason, regular, periodic blow-downs of some of the concentrated water are very important. Following this procedure as recommended provides stable cylinder water conductivity as well as minimal water loss for the expected service life of the cylinder.

Water blow-down is performed by a blow-down pump (32). The functioning of the blow-down pump is continuously monitored during operation. If the pump is damaged, the steam humidifier shuts down.

With normal water quality, the blow-down loss rate is between 7% and 15% of the amount of steam produced. The steam cylinder requires complete drainage every 3-8 days, regardless of the water quality.

Mineral deposits settle in the open area below the electrodes and are removed through periodic maintenance. The blow-down pump itself has wide openings and can flush out smaller pieces of mineral deposit. This extends the service life of the unit and reduces the required maintenance interval.

During blow-downs, water flows from the pump into the drainage system.

A sensor electrode (10) monitors the maximum water capacity of the cylinder. When the water level reaches the sensor electrode, the water supply is interrupted. This can occur when the water has low conductivity or when the electrodes are worn out. In the case of low water conductivity, however, this state usually lasts only a short time. The built-in control and the large area electrodes combine to produce a rapid rise in conductivity by increasing the concentration of the water.

The steam cylinder consists of a top (16) and lower (19) part joined with a cylinder flange. The seal between the cylinder and cylinder base (37), as well as between the top and lower part of the cylinder, is maintained using an o-ring (35+17).

For maintenance the cylinder can be drained by pressing the control switch „Pos.II”.

5. Installation



Warning: Installation of this unit to be attempted only by qualified personnel. We accept no liability for damage due to faulty installation.

Obey all safety notes and warnings present on the unit.

During installation the unit must be disconnected from its power supply.

Attaching or installing additional components is permitted only with the written consent of the manufacturer, or else the warranty is void.



Warning: If the installation of this unit is attempted by only one person there is a risk that the unit drops down. We propose to carry out the installation by two persons.

5.1 Steam Humidifier Operating Environment



Note: When selecting the installation site for the steam humidifier, note that:

- Ambient temperature must be between +5° and +40° C. Relative humidity must not exceed 80% RH.
- An Installation in a closed room requires aeration and if necessary temperature conditioning in order to reach the above mentioned environmental conditions.
- The minimum clearances indicated in the diagram below must be observed; these are necessary to ensure adequate ventilation for the housing.
- HygroMatik humidifiers are not suitable for direct outdoor installation.
- The steam humidifier should be installed as close as possible to the steam manifold. Optimal performance is guaranteed only with short lengths of steam and condensate hose.
- Hoses must be laid at a consistent 5-10% incline to prevent sagging and kinking.
- The rear panel of the steam humidifier heats up during operation (to a maximum of 60°C). Take care that the construction on which the unit is mounted is not made of temperature-sensitive material.
- Place the steam humidifier so that the unit is easily accessible with sufficient space to perform maintenance.
- The steam humidifier is not qualified for exterior applications.

5.1.1 Fitting

Wall Mounting



Note: To function properly the steam humidifier must be installed vertically.

- » Position the steam humidifier in the planned location, adjust with spirit level and mark position of hanging bolts.
- » Hang the unit onto bolts screwed into the marked position and tighten.

If there is no suitable wall, it is recommended that the equipment is installed on brackets which can be embedded in the floor.



Note: The C45Kit cannot be used for wall mounting. The installation has to be done on brackets.

Wall Mounting

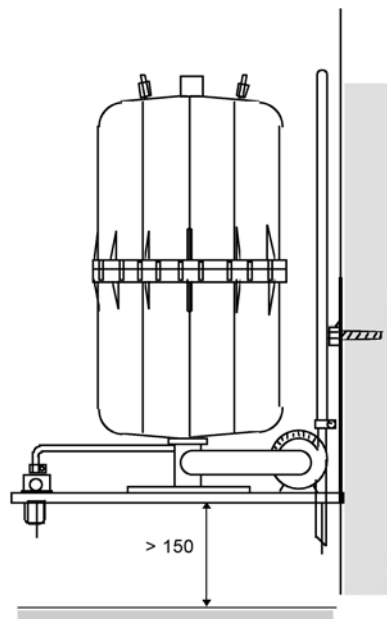

Note: To drain properly drain hose system of C17Kit until C45Kit must be fixed straightly above bracket.



Warning: If the installation of this unit is attempted by only one person there is a risk that the unit drops down. We propose to carry out the installation by two persons.

5.1.2 Equipment Dimensions CompactLine Kit

Dimension [mm]	C01 Kit	C02 Kit	C06 Kit	C10 Kit	C17 Kit	C22 Kit	C30 Kit	C45 Kit
x	270	270	270	270	328	328	328	330
y	310	287	365	413	575	577	575	615
z	175	175	175	175	254	254	254	316
a	27	27	27	27	47	47	47	49
b	35	35	35	35	55	55	55	30
c	128	128	128	128	307	307	307	307
d	20	20	20	20	23	23	23	23
f	400	400	400	400	620	620	620	670

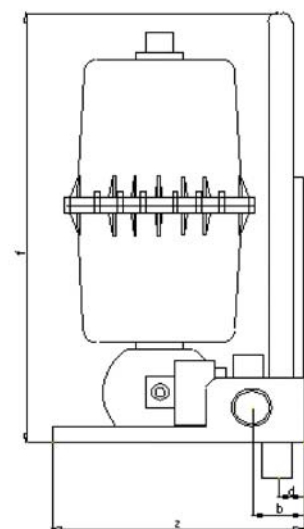
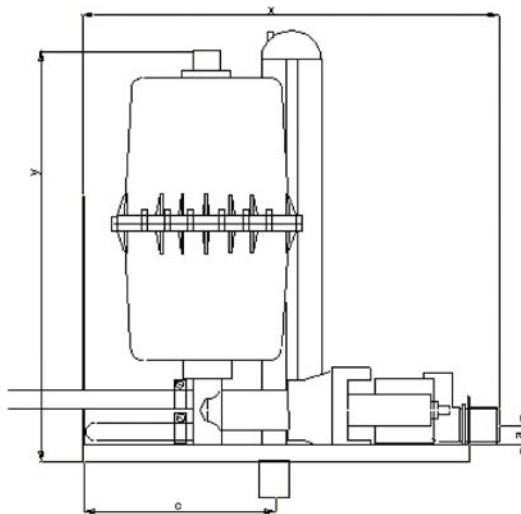
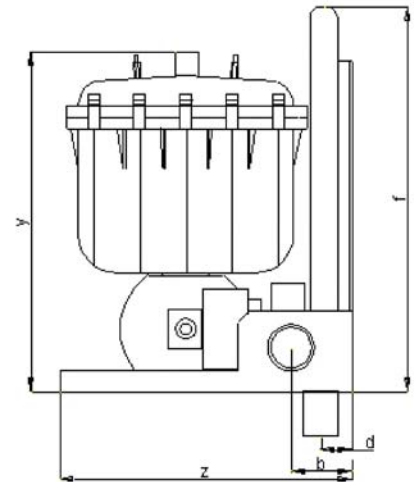
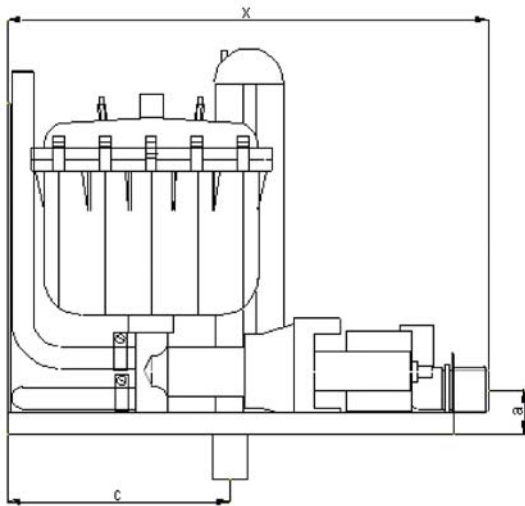

5.2 Fan Unit (optional)



Note: The fan unit should be positioned to avoid drafts. In general, a minimum height of 2 m is sufficient.

Install the fan unit directly on a wall.

Fan Unit	Type
for wall installation	VG 08, 17, 30



Warning:

- During operation and a soon afterwards the steam nozzle is hot! If touched this can cause burns to the skin.
- During operation the cross-flow fan rotates. Do not touch the fan during operation.
- During operation hot steam discharges from the nozzle. In the field of the visible steam cloud contact can cause burns to the skin.

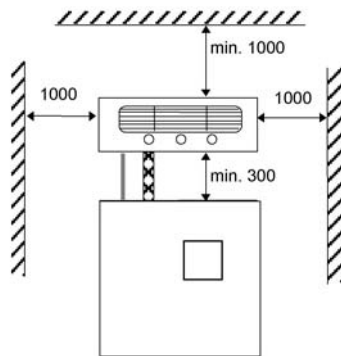

Front View Wall Installation

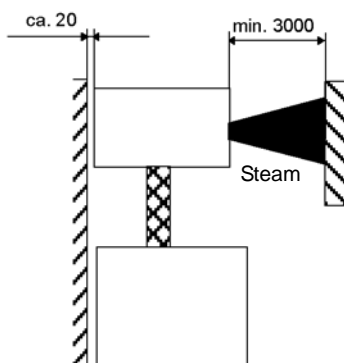

Side View Wall Installation

5.2.1 Fan Unit Type VG

- Install the fan unit over the steam humidifier.
- When employing multiple fan units, do not exceed a maximum distance of 5 m from the steam humidifier.
- Observe the clearances specified in the diagram below:

Technical Specifications Fan Unit VG				
Fan Unit		VG08	VG17	VG30
Quantity of Steam	[kg/h]	8	17	30
Steam Inlet	[mm ϕ]	25	25	40
Condensate Outlet	[mm ϕ]	12	12	12
Airflow Capacity	[cbm/h]	185	185	350
Nominal Output	[W]	35	35	67
Nominal voltage	[V]	230	230	230
Dimensions	W [mm]	441	507	550
	H [mm]	171	171	171
	D [mm]	180	237	277
Weight	[kg]	4,5	6	7
Sound Level (1m distance to the source of noise)	[dB(A)]	50	53,8	59

5.3 Absorption Distance B_N

The "absorption distance" (B_N) is defined as the distance from the steam feed to where the steam is completely absorbed in the treated air. Inside the absorption distance, steam is visible as mist in the air stream.

Condensation may collect on anything installed inside the absorption distance.

Although steam outside the absorption distance (B_N) is completely absorbed, it is not yet evenly diffused in the duct. If you plan to install any parts or devices inside the absorption distance, such as sensors or elbows, we recommend increasing the absorption distance using the formulae below. The absorption distances required for certain installed fittings are distinguished by separate symbols and calculated as a multiplier of the absorption distance B_N .

Absorption Distance	
B_N	for normal obstructions, such as sensors, ventilators, outlets
$B_C = (1,5...2) \times B_N$	for fine filters, heat registers
$B_S = (2,5...3) \times B_N$	for particle filters
$B_D = (2,5...3) \times B_N$	for humidity sensors, duct humidistats

The absorption distance has no fixed value, but depends on many factors. These are depicted in the absorption distance nomogram below.

5.3.1 Determining the Absorption Distance

To determine the absorption distance, the following parameters are required:

- Air humidity before humidification x_1 in g/kg.
- Air temperature after humidification t_2 in °C (with steam humidifiers the change in air temperature due to humidification may be disregarded t_1 or t_2).
- Specific increase in humidity Δx in g/kg (can be determined in the h,x diagram)
- quantity of steam introduced $\overset{o}{m}_D$ in kg/h.
- air speed w_L in m/s in air duct
- Total length l_D of the steam manifold installed in the air duct

Length l_D of the usable steam manifold depends on the dimensions of the air duct. The length of the absorption distance can be reduced by using multiple steam manifolds (also see section on the steam manifold).

Method:

Graphically determine absorption distance B_N using the absorption distance nomogram (also see Section „Absorption Distance Nomogramm“). Enter the value of the parameters enumerated above into the respective quadrants. The resulting point of intersection indicates the value of the desired absorption distance B_N .

Notes:

- Air humidity before humidification x_1 : _____ [g/kg]
- Air temperature after humidification t_2 : _____ [°C]
- Specific increase in humidity Δx : _____ [g/kg]
- quantity of steam introduced $\overset{\circ}{m}_D$: _____ [kg/h]
- air speed w_L : _____ [m/s]
- Total length of the steam manifold l_D : _____ [mm]

5.3.2 Absorption Distance Nomogram

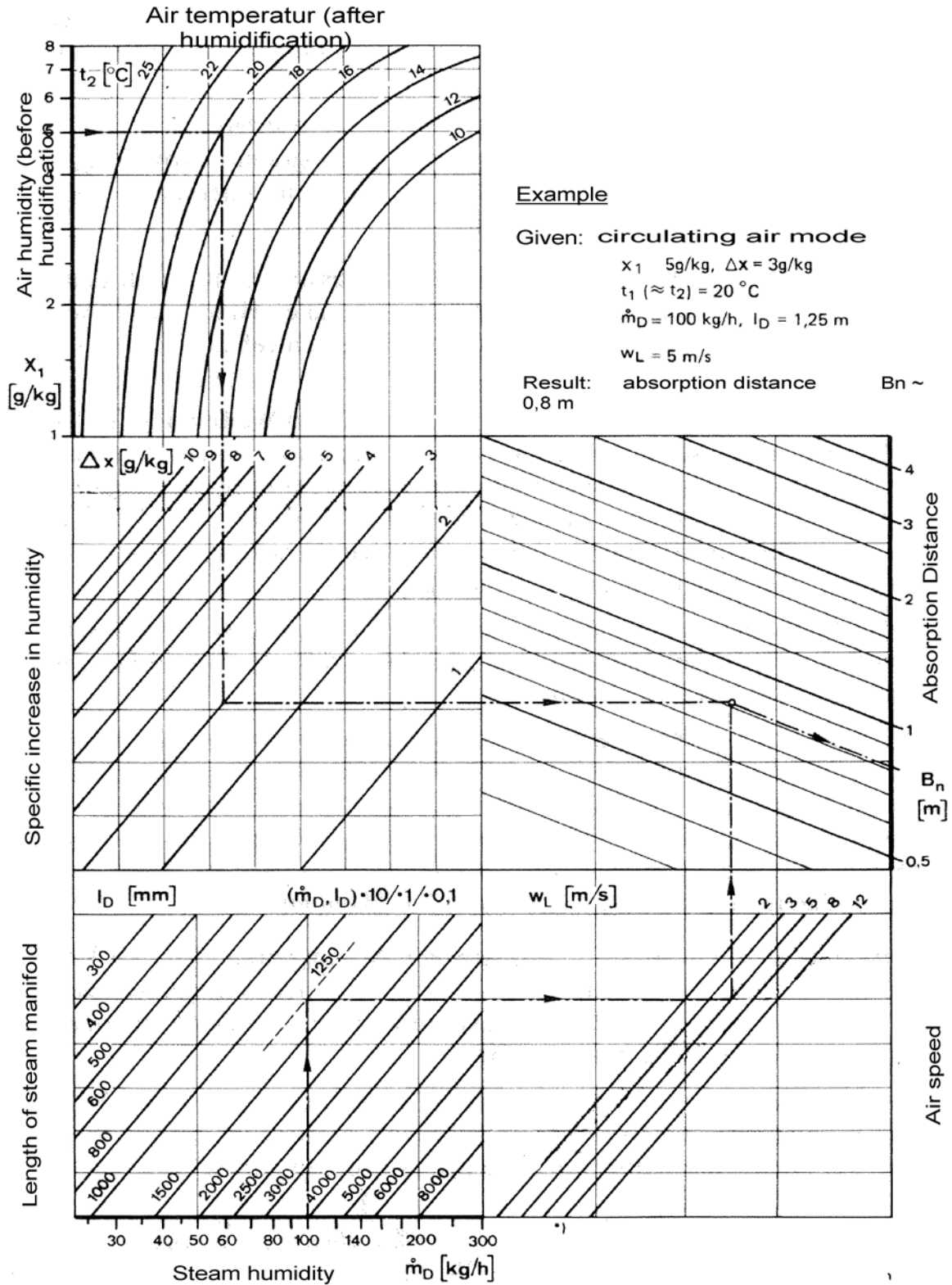

Source: Henne, Erich: Luftbefeuchtung (Air Humidification), 3rd Edition 1984 (Page 101), Oldenbourg Industrieverlag, Munich

5.4 Steam Manifold

5.4.1 Notes on Installation

Horizontal installation of steam manifold

These notes are based on a homogeneous Standard steam manifold installation:

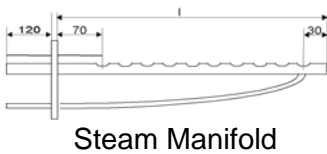
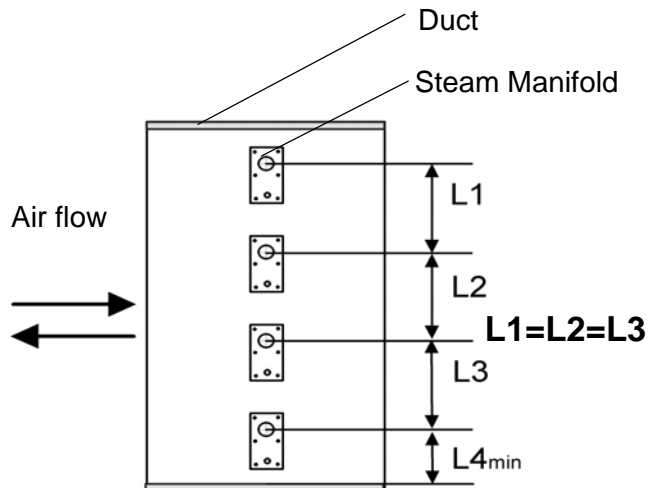

An even distribution of steam manifolds ensures a uniform steam distribution.

Please use the total height of the duct!

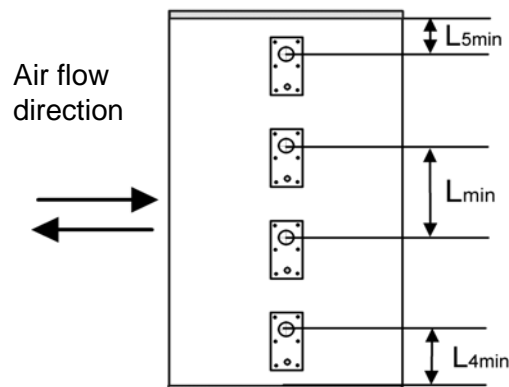

Minimum distances in order to avoid condensation:

L_{min} = 210mm: distance „ steam manifold - next steam manifold“

L4_{min} = 120mm: distance „lowest steam manifold - duct bottom“:**L5_{min} = 120mm:** distance „highest steam manifold - duct ceiling“

Installations depending on special designs of air ducts:

Air duct	Positioning of steam manifolds	Sample																								
flat	Staggered vertically and laterally																									
very flat	<p>By tilting the steam manifold 30 - 45° towards the air flow direction, the minimum upper clearance can be reduced to 70mm.</p> <table border="1"> <thead> <tr> <th colspan="2">min. distances:</th> <th colspan="2">H1[mm]</th> <th colspan="2">H2[mm]</th> </tr> <tr> <th></th> <th></th> <th>30°</th> <th>45°</th> <th></th> <th></th> </tr> </thead> <tbody> <tr> <td>DN25</td> <td></td> <td>182</td> <td>168</td> <td>225</td> <td></td> </tr> <tr> <td>DN40</td> <td></td> <td>193</td> <td>179</td> <td>230</td> <td></td> </tr> </tbody> </table>	min. distances:		H1[mm]		H2[mm]				30°	45°			DN25		182	168	225		DN40		193	179	230		<p>very flat duct</p>
min. distances:		H1[mm]		H2[mm]																						
		30°	45°																							
DN25		182	168	225																						
DN40		193	179	230																						
narrow, high	Identical lengths one on top of the other. Staggered laterally if possible.																									
square	Identical lengths, staggered vertically and laterally																									
low, very wide	facing each other																									

Vertical installation of steam manifold

Steam manifold placement:

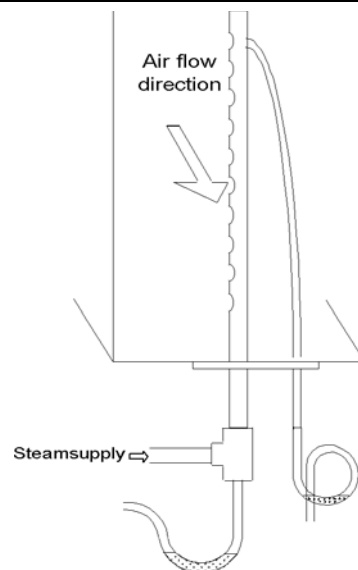

Horizontal installation of the steam manifolds is preferred. However, installation from below into the air duct is possible.

Note:



- Install the steam manifold horizontal with it ensure a clean steam out.
- Maximum allowable pressure in the air duct is 1200 Pa.
- On the return side, the maximum allowable negative air pressure is 500 Pa. Placement of the steam manifold on the supply side of the air duct is preferred.
- With high-pressure air-conditioning systems, the unit's drain hose system must be modified depending on the over pressure. When this is the case please consult HygroMatik.
- Install the steam manifold as close as possible to the steam humidifier in order to minimize steam loss through condensation.
- Depending on the design of the air duct, additional mounting of the steam manifold may be required. Shown installation and position dimensions are based on experimental values. Special environmental conditions could require adjustments.
- We note that the German Association of Engineers (VDI) Guideline 6022 specifies a water drain within the absorption distance inside the air duct.
- For steam bath applications: Install the steam manifold safe from contact with people in order to prevent injuries or burns. Do not install the steam manifold near a temperature sensor or inaccurate readings may result.
- Air flow rates over 3m/s can possibly lead to condensate drainage problems at the steam manifolds which may require adaptation measures.

Length of steam manifold [mm]*:

I	220	400	600	900	1200	1450
DN25	x	x	x	x	x	x
DN40	x	x	x	x	x	x

* special lenght on request

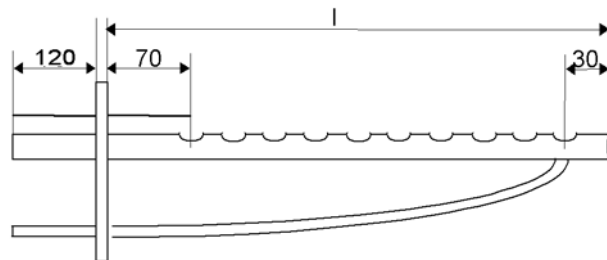

Note: At lengths of 600mm or more, steam manifolds are shipped with an extra alternative mounting fixture (Nut, M8) on the closed end.

The number and size of appropriate steam manifolds, as well as the nominal width of their respective steam and condensate hoses, are found in the tables below.

HyLine:

Type	Steam Manifold	Steam Hose	Condensate hose
HY05-HY17	1xDN25	DN25	DN12
HY05DS - HY17DS (for SPA)	1xDN40	DN40	DN12
HY23-HY30	1xDN40	DN40	DN12
HY45-HY60	2xDN40	2xDN40	2xDN12
HY90-HY116	4xDN40	4xDN40	4xDN12

CompactLine:

Type	Steam Manifold	Steam Hose	Condensate Hose
C01-C17	1xDN25	DN25	DN12
C10-DS, C17DS (for SPA)	1xDN40	DN40	DN12
C22, C30	1xDN40	DN40	DN12
C45**	2xDN40	DN40	DN12
C58	2xDN40	2xDN40	2xDN12

HeaterCompact/Kit:

Type	Steam Manifold	Steam Hose	Condensate Hose
HC02/Kit	1 xDN25	DN25	DN12
HC03-12*	1xDN25	DN25	DN12
HC03-12/Kit	1xDN40	DN40	DN12
HC16-27/Kit	1xDN40	DN40	DN12
HC3-27 (for SPA)	1xDN40	DN40	DN12

CompactLine Kit:

Type	Steam Manifold	Steam Hose	Condensate Hose
C01 Kit - C06 Kit	1x25	DN25	DN9
C10 Kit - C17 Kit	1x25	DN25	DN12
C22 Kit / C30 Kit	1x40	DN40	DN12
C45 Kit	2x40	DN40	DN12

HeaterLine:

Type	Steam Manifold	Steam Hose	Condensate Hose
HL 6-12 *	1xDN25	DN25	DN12
HL 6-12 (for SPA)	1xDN40	DN40	DN12
HL 18-30	1xDN40	DN40	DN12
HL 36-45 **	2xDN40	1xDN40	1xDN12
HL 60-90 ***	2x(2xDN40)	2x(1xDN40)	2x(1xDN12)

* For units HL 6 - 12 and HC3-12 HygroMatik delivers one adapter DN40 / 25 (but not for SPA applications)..

** For units HL 36 - 45 HygroMatik delivers one t-connector for separating the steam on two steam manifolds.

***HL 60.-90 are double units and consist of HI 30-45 units.

5.5 Steam Line



Note: When installing the steam hose, please pay attention to the following:

- The steam hose diameter may not be smaller than the steam outlet of the HygroMatik steam humidifier (do not restrict the cross-section, otherwise back pressure will increase).
- The steam hose must be without sags and kinks and be laid with a continuous slope of 5-10% (otherwise sags will be formed).
- The steam hose should be as short as possible. In case of lengths of over 5 m the hose should be insulated to avoid excess condensation.
- In the case that steam output is distributed on two steam manifolds the T-pieces for the steam and condensate hose should be installed near the manifolds. If the installation is carried out in this way only one steam hose is necessary for the main part, loss of condensate will be decreased.
- Depending on how the hose is laid, hose clips should be set at intervals of approx. 500 mm.
- Allow access to the steam hose, so that it can be inspected later.
- In case of straight lengths of several meters, it is recommended to place the steam hose in temperature resistant plastic pipe (40 mm dia for hose DN25; 60 mm dia for hose DN40) or to use copper pipe.
- Only genuine HygroMatik hoses are capable of withstanding the operating conditions. Allow for minimum bending radii:
Steam hose DN 25: $R_{min} = 200 \text{ mm}$
Steam hose DN 40: $R_{min} = 400 \text{ mm}$

5.6 Cover Plate

HygroMatik flange plates may be used to neatly complete installation of the steam humidifier in the air duct.

Two-piece flange plates are available for the DN25 and DN40 steam manifolds.

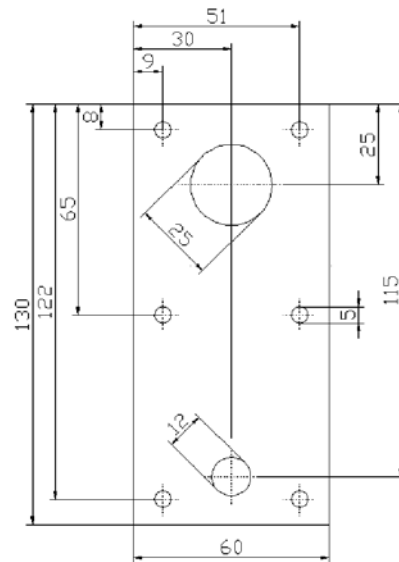

flange plate DN25 E-2604260

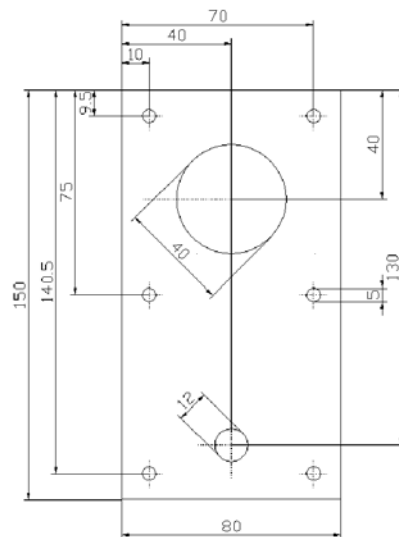

flange plate DN40 E-2604410

5.7 Drill Pattern

5.7.1 Drill Pattern DN25 (not to scale)

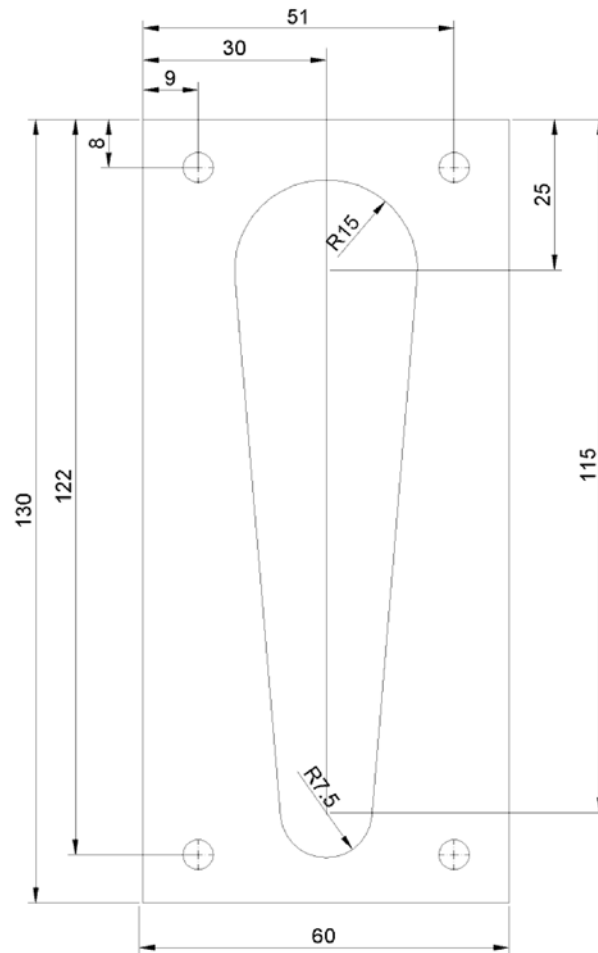

Note: Due to variable print media the dimensions are not to scale.

5.8 Condensate Hose



Note: When installing the condensate hose, please pay attention to the following:



Warning: To keep condensate from accumulating in the duct, make sure condensate can drain freely.

If the steam manifold is positioned higher than 500 mm above the steam humidifier:

- » Remove the condensate plug (12) from the connection fitting on the cylinder.
- » Lay the condensate hose at an approximate incline of 5-10% to the steam cylinder connection fitting, to allow the condensate to drain freely.



Note: It is recommended to form a loop of 200 mm diameter as a vapour trap provided there is enough space. The loop should be filled with water before commissioning.

If the steam manifold is positioned lower than 500 mm above the steam humidifier:

- » The condensate must be drained separately.
- » To prevent steam loss, lay a loop at least 200 mm in diameter. The loop should be filled with water before commissioning.
- » To ensure condensate drainage, place the loop (vapor trap) as far away as possible below the steam manifold connection.
- » The condensate connection on the steam cylinder (16 + 19) must be closed with a sealing cap.
- » Place hose clamps at intervals of at least 500 mm, depending on how the hose is laid.

5.9 Types of Installation

The steam manifold is positioned higher than 200 mm above the steam humidifier.

- » Lay the steam hose at a height of at least 400 mm and then connect to the steam manifold with a constant rise or fall.
- » Lay condensate hose with a slope to the steam cylinder.

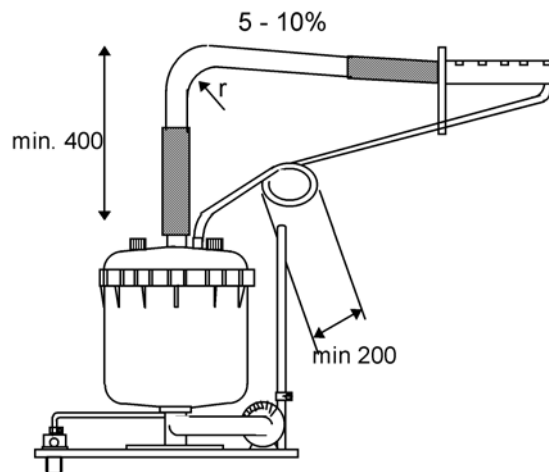

Steam hose with falling slope

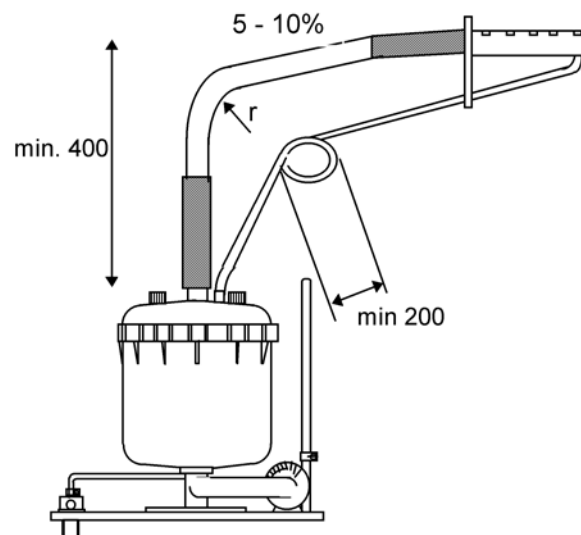

Steam hose with rising slope

Steam manifold is positioned below the steam humidifier.

- » Lay steam hose at a height of at least 400 mm and then connect to the steam manifold with a constant fall.
- » Lay condensate hose with a loop of 200 mm diameter to the drain.

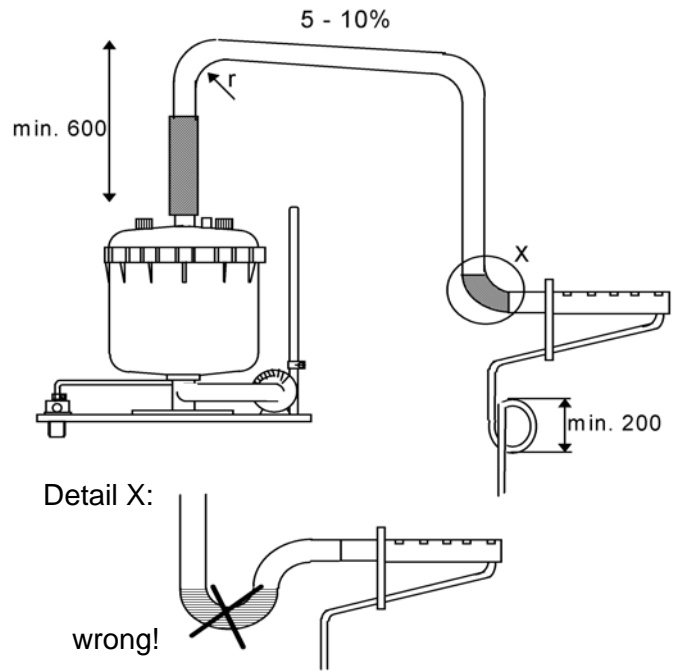

5.10 Steam Solenoid Valves

When humidifying a number of loads, which are to be controlled separately, using a single steam humidifier, steam solenoid valves can be included in the steam hoses. Valve control has to be provided by the customer.

- Install the vertical risers with flow from bottom to top.
- The best position is just above the steam humidifier.

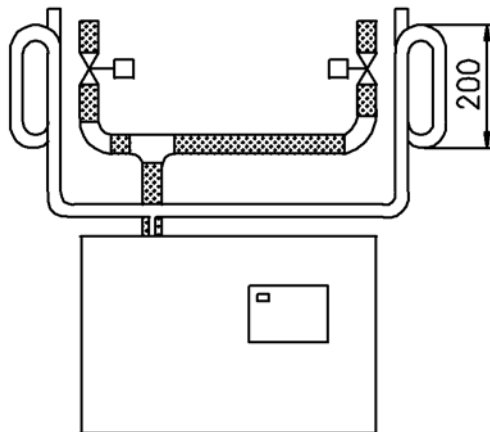

Installation of Steam Solenoid Valve

5.11 Unit Installation Check



Attention: This unit may only be operated by qualified and properly trained personnel.

Please check the installation using the following list:

- Does unit hang vertically?
- Are wall distances to the unit within the range
- Does steam hose have a slope of 5-10%?
- Is condensate hose installed with a loop of min. 200 mm?
- Is steam manifold positioned correctly? Are all bolts and clamps tightened?

6. Water Installation



Warning: When installing the water installation, note the following:

- Have all work performed by a professional.
- Disconnect power supply before installation.
- Obey local public utility regulations
- Verify that necessary safety measures have been taken – in compliance with either German Technical and Scientific Association for Gas and Water (DVGW) guidelines (DIN EN1717) or local regulations – to eliminate backflow of polluted water into drinking water treatment facilities. This can mean installing a backflow preventer. Within the humidifier, a double check valve (58) is located in the water supply line. It prevents - in accordance with DIN EN 61770 - the backflow of water.
- Use feed water without chemical additives and with a conductivity between 200 and 800 $\mu\text{S}/\text{cm}$ only. Above conductivity levels of 800 $\mu\text{S}/\text{cm}$ to a maximum of 1250 $\mu\text{S}/\text{cm}$ and below conductivity levels of 200 $\mu\text{S}/\text{cm}$ to a minimum of 125 $\mu\text{S}/\text{cm}$, special adjustments are required. In this case please contact HygroMatik.
- The water supply temperature may not exceed 40° C.
- Water installation pressure: 1 - 10 bar (100 x 10³ to 100 x 10⁴ pascal).
- Blow-down water must be able to drain.
- For water installation please use the water connecting hose that is delivered with the unit.

6.1 Operation with Softened Water



Warning: Unless special measures are taken, feeding softened water into the HygroMatik steam humidifier is dangerous. It can cause

- unacceptably high conductivity
- the formation of salt bridges between the electrodes and the electrode leads on the inner surface of the top part of the steam cylinder
- foaming in the steam cylinder

Salt bridges cause electrical arcs. These are indicated by the presence of black grooves in the top part of the cylinder. The top part must be replaced to prevent further damage to the cylinder material, as well as short circuits which trip main circuit breakers.

Foam comes into contact with the maximum water level sensor electrode and triggers a signal indicating the cylinder is filled to capacity, even though this is false and the nominal current has not yet been reached.



Note: Please contact HygroMatik if you wish to operate the unit with softened water.

If using a water softening system, we recommend diluting the softened water with normal tap water to produce an overall hardness between 4-8°dH. This value can be set lower if the water does not foam.

When blending softened water with deionized water (conductivity = 5-20 µS / cm) it is to ensure that the mixture neither foams nor is too low in conductivity.

When feed water contains softened water, the level of conductivity is typically higher at operating temperature. Install a HygroMatik "cylinder star" to extend the service life of the electrodes.

6.2 Water Supply

- » Install a shut-off valve (SV) in the supply line.
- » Install a water filter (WF) if water quality requires it.



Note: Shut-off valve (SV) and water filter (WF) are not supplied with the unit

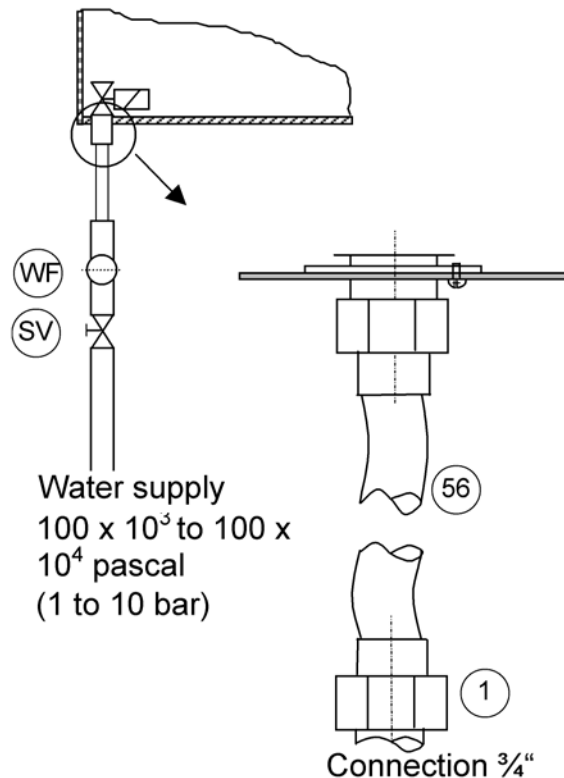

- » HygroMatik provides a water hose (56) with a cap nut at both ends which can be used for water installation.
Install as follows:

- » Screw and tighten the cap nut with its inner seal ring around the water supply screw connection that protrudes from the base.



Note: Tightening too much will destroy the fitting. The valve strainer must be placed inside the solenoid valve.

- » Use a cap nut (internal thread 3/4") with inner seal for a customer-provided water installation.

6.3 Water discharge

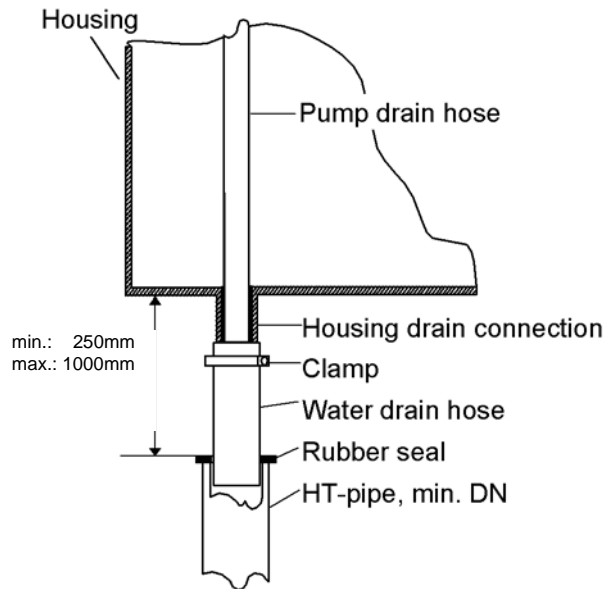

Warning: During blow down hot water with a temperature of about 95°C is being drained. If touched this can cause burns to the skin.



Warning: Pay attention for free and non-pressure drainage of the water! During blow down up to 0,3 L/sec are being drained. For water discharge, we recommend installation of a flexible water drain hose. Humidifier and wastewater discharge must be on the same pressure level.

Please note:

- Do not bend the drain hose.
- Install discharge line and drain pipe made from temperature resistant material (to 95° C).

Install water discharge as follows

- Loosely insert a length of 1 1/4 " drain hose, approx. 250 - 1000 mm, into a drain pipe with a minimum inner diameter of 40 mm and seal with a rubber gasket.
- Fit water drain hose over the pump drain hose and fasten to the housing drain connection.

A grounding clip is fixed on the inner surface of the housing drain connection. The end of the pump drain hose is pushed into this clip. During blow-down, the grounding clip is in direct contact with the water and shunts potential residual electric currents away from the housing.

There is a 3mm-wide crack between the pump drain hose jacket and the inner surface of the housing drain connection. If water collects in the base plate, it will flow through this crack into the drainage system.

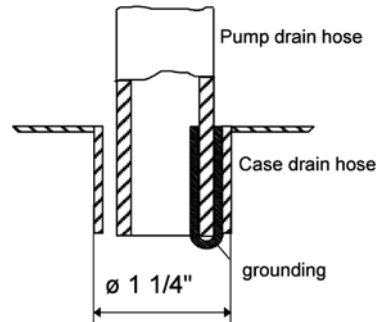

6.4 Water Installation Check

Go down the following water installation checklist:

- Are all screws and clamps properly tightened?
- Is the water supply pipe flushed?
- Was the water installation correctly installed?
- Can the blow-down water drain freely?
- Was the water discharge correctly installed?
- Is there no leakage from the water supply pipe and water discharge?



Warning: Flush the water supply pipe before connecting to the solenoid valve, especially a newly installed pipe. This prevents premature damage.

7. Electrical Connection



Danger, Hazardous Voltage: All work related to electrical installation to be performed by authorized personnel only (electricians or professionals with equivalent training). The customer is responsible for checking qualifications.



Danger, Hazardous Voltage: Do not plug the steam humidifier into the power grid until after all installation work has been completed.

Please obey all local regulations concerning electrical installation.



Warning: The electronic components of the humidifier control are very sensitive to electrostatic discharges. In order to protect these components during any type of installation, steps must be taken to guard against damage from electrostatic discharge (ESD protection).



Warning: For electrical installation, note the following:

- Disconnect power supply before installation and protect against restart.
- Verify the absence of electric current.
- Make sure the unit is switched off before installing or removing the display plate or basic PCB.
- Professionally lay electrical connector cable.
- Install the electrical connections according to the wiring diagram.
- For units with rated power over 33 kW, only a permanent connection to a permanent wire is allowable (German Association for Electrical, Electronic & Information Technologies [VDE] Standard 0700 Section 98).
- Verify that all terminals have been tightened.

7.1 Electrical Installation

- » Fuses must have a contact gap of at least 3mm per pole.
- » Install a separate main connection for each steam cylinder, complete with main contactor, main switch, etc.
- » Connect potential equalization to the outer ground bolt.
- » Observe the German Association for Electrical, Electronic & Information Technologies [VDE] Standard 0100 when selecting a connection cross section.
- » Install main power supplies as follows:

HyLine:

Type	Main Power Supply
HY05 - HY45	1 x 400V/3Phase/N
HY60 - HY116	2 x 400V/3Phase/N

CompactLine:

Type	Main Power Supply
CompactLine	1 x 400V/3Phase/N

MiniSteam:

Type	Main Power Supply
MS5	1 x 400V/3Phase/N
MS10	
MS5	1 x 230/1Phase/N

CompactLine Kit:

Type	Main Power Supply
C01Kit, C02Kit	1 x 230V/1Phase
C06Kit - C45Kit	1 x 400V/3Phase/N

Other voltages are available on request.

We recommend employing quick or medium blow main fuses (applicable only to the grid voltages above). See table below indicating maximum power usage for each circuit protection:

HyLine:

Type	Power Usage	Circuit Protection
HY05	5,4 A	3 x 6A
HY08	8,7 A	3 x 10A
HY13	14,1 A	3 x 16 A
HY17	18,4 A	3 x 20 A
HY23	24,9 A	3 x 35 A
HY30	32,5 A	3 x 35 A
HY45	48,8 A	3 x 63 A
HY60	2 x 32,5 A	6 x 35 A
HY90	2 x 48,8 A	6 x 63 A
HY116	2 x 62,8 A	6 x 63 A

CompactLine:

Type	Power Usage	Circuit Protection
C6	6,5 A	3 x 10 A
C10	10,8 A	3 x 16 A
C17	18,4 A	3 x 20 A
C22	23,8 A	3 x 35 A
C30	32,5 A	3 x 35 A
C45	48,8 A	3 x 63 A
C58	62,8 A	3 x 63 A

MiniSteam:

Type	Power Usage	Circuit Protection
MS5, 230V/1/N	15,7 A	1 x 16 A
MS5, 400V/3/N	5,4 A	3 x 6 A
MS10, 400V/3/N	10,8 A	3 x 16 A

CompactLine Kit:

Type	Power Usage	Circuit Protection
C01Kit	3,3 A	1 x 6 A
C02Kit	6,5 A	1 x 10 A
C06Kit	6,5 A	3 x 10 A
C10Kit	10,8 A	3 x 16 A
C17Kit	18,4 A	3 x 25 A
C22 Kit	23,8 A	3 x 25 A
C30Kit	32,5 A	3 x 35 A
C45Kit	48,8 A	3 x 63 A

7.2 Safety Interlock



Note: Install contact interlocks, i.e. max. hygrostat, vane relay, pressure controller, air interlock, in series between terminals 1 and 2.



Warning: A max-hygrostat should be installed in the safety interlock. The max-hygrostat acts as a safety device in case the humidity sensor malfunctions.



Warning: Contacts laid between terminals 1 and 2 must be potential free and rated for 230V switches.

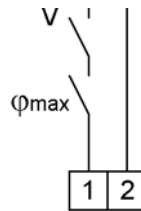

7.3 Wiring Diagram

Please remove the wiring diagram from the technical manual supplied with the control used with your humidifier. Every steam humidifier comes with one technical manual for the unit and one for the control.

7.4 Electrical Installation Checklist

Perform electrical installation checks in compliance with customer site requirements and public power utility regulations:

- Is the power grid voltage compatible with the voltage on the name plate?
- Have all electrical connections been made according to the terminal connection diagram?
- Have all electrical cable and plug connections been properly tightened?
- Are all electrical socket connections secure?
- Is the unit grounded?

After this check the unit can be switched on.



Warning: The unit must be closed and locked. This guarantees that the cover is grounded. (only humidifier type HyLine and MiniSteam)



Note: For initial operation, control, service, malfunctions, and circuit diagrams, consult the operation instructions for the Hygro-Matik-controls.

8. Maintenance

The HygroMatik steam humidifier is easy to maintain. However, inadequate or improper maintenance can lead to operational malfunctions. Perform regular maintenance to give your unit a long life span.



Warning: When performing maintenance work, please note:

- During operation and also for a while after switching off the unit the steam cylinder is hot. Before touching the cylinder, check its temperature.
- Drained cylinder water could have a temperature up to 95°C.
- Leakages within the humidifier could lead to leakage currents.
- Observe safety notes.
- Switch off the unit before maintenance and protect against restart.
- After maintenance work, have qualified personnel check that the unit is operating safely.

The steam humidifier's performance and maintenance intervals primarily depend on the water quality (carbonate hardness, conductivity) and the quantity of steam produced since the last maintenance. Abnormal water quality can shorten or lengthen maintenance intervals. Ongoing maintenance intervals can be estimated based on the amount and type of residue found in the steam cylinder.

Indications that cylinder maintenance is required immediately include:

Control	Indicator
L	maintenance message: red LED is blinking: - Cylinder-Full, delayed *, - Blow-down Fault *, - Filling Fault *. Unit has switched itself off automatically.

8.1 Maintenance Work

Mineral deposits precipitate and crystallize very differently in different types of water, even when two types have the same conductivity and hardness levels (the various constituents in the water interact differently).

Instructions on maintenance and cleaning intervals, or on electrode service life, are based entirely on empirical data.

Cycle	Maintenance Work
4 Weeks after initial operation (with normal water quality)	Visual inspection of electrical and mechanical connections Remove mineral deposits from steam cylinder, water drain hose and blow-down pump Check electrodes for erosion
Semiannually (with normal water quality and "normal" operation = 8h/day)	Visual inspection of electrical and mechanical connections Remove mineral deposits from steam cylinder, water drain hose and blow-down pump und ggf. erneuern Check electrodes for erosion

In most cases, the conductivity levels given in Section 1.1 "Directions for Use" of these instructions can be considered normal. Individual parameter setting of the control may be necessary.

In extreme cases, water pretreatment may be necessary (softening by dilution to approx. 4 - 8 °dH; decarbonization/partial desalination to achieve target reductions in carbonate hardness). HygroMatik would be pleased to refer you to companies specializing in water treatment systems.



Warning: Both the clamps that fix the steam cylinder halves and the electrodes have sharp edges and angles that possibly could lead to cut injuries.

8.1.1 Cleaning the Steam Cylinder

Disassembly

- » Drain residual water in the cylinder.
- » Press the on/off control switch in position "II".
- » Disconnect steam humidifier from power supply. Control switch OFF and remove safety fuse F1. Secure against restart.
- » Check that unit is without power.
- » Lift steam cylinder (16+19) out of base (37) and remove from humidifier.
- » Release its flange clamps (8) and open the cylinder.

Cleaning



Note: When cleaning do not use acids or other chemicals!

- » Remove all scale and sludge from cylinder.
- » Remove deposit from the heating electrodes (3) by knocking them (small amounts that remain are acceptable).
- » Inspect the inside of the top part of the cylinder for furring and any electrical bridging (black grooves) between the electrodes and their bushings and remove completely by washing.



Note: Top half of the cylinder must be replaced if electrical bridges have penetrated deeply into the material.

- » Clean cylinder coarse strainer.
- » Restore the surface of the level electrode in the top part of the cylinder to a bright metal condition.

Reassembly

- » Replace the flange o-ring (13) with original HygroMatik solvent-free, moistened o-ring.



Note: When joining the cylinder the upper and lower parts must have a firm fit.

- » Connect upper (16) and lower parts (19) with clamps (18).

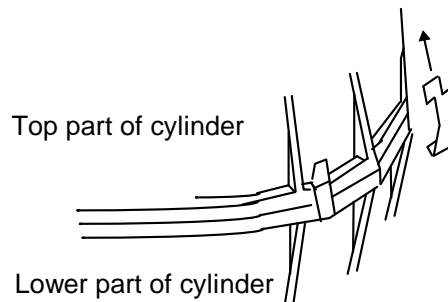

- » Remove o-ring (35) from the lower part of the cylinder.
- » Insert a new solvent-free, moistened HygroMatik o-ring (35) into the cylinder base.



Note: The types C02Kit and C06Kit are supplied with a steam hose adapter (1). Exchange o-ring if maintenance steam cylinder.

- » Refit cylinder firmly into cylinder base (37).
- » Connect plug (9) to level sensor.
- » Connect plugs (10) to electrodes.



Attention: Check the electrode plugs on the electrodes for firm seating.



Note: Connect the electrode plugs with the matching electrodes. Pay attention to the coloured hand nuts (9)!

- » Push in safety fuse.

Switch on the unit and operate for 15 to 30 minutes. Check for any leaks.

8.1.2 Electrode Wear

Electrode wear is dependent on:

- feed water quality (conductivity and hardness) and
- generated amount of steam.



Attention: The electrodes must be exchanged at the latest if the display shows the message Service (red LED is blinking). The unit is switched off in case it senses a period of one hour's operation in the "Cylinder full" condition. As a guide they must still be a third to one half their original length.

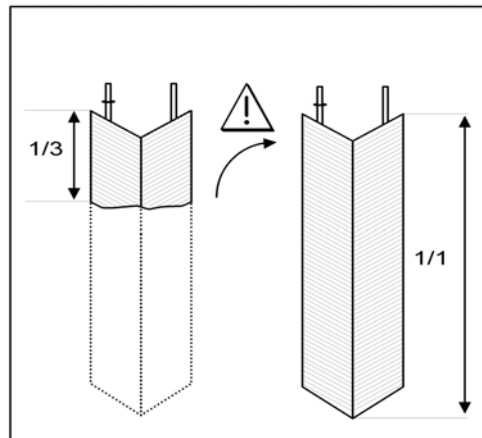

The original length of HygroMatik stainless steel large-area electrodes is as follows:

Type	length [mm]
C01Kit	115
C02Kit	80
C06Kit	125
C10Kit	155
C17Kit-C45Kit	235

Uneven Electrode Wear

Replace badly worn electrodes completely. Check main fuses !

If a main fuse has blown the corresponding electrode will not be supplied with power and hence will not wear.

8.2 Replacing Electrodes



Note:

- If electrodes must be exchanged frequently or
- black sludge collects in the cylinder or
- there is arcing in the cylinder

this indicates, that the conductivity of the water is too high, or the cylinder is not being drained frequently enough. In this case please contact HygroMatik for advice.

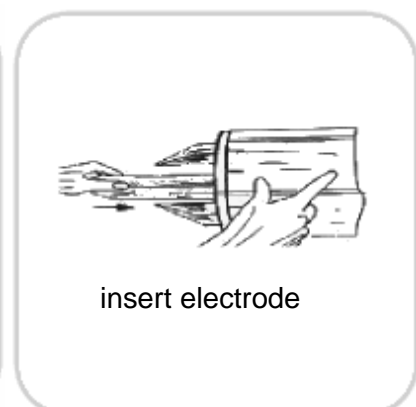
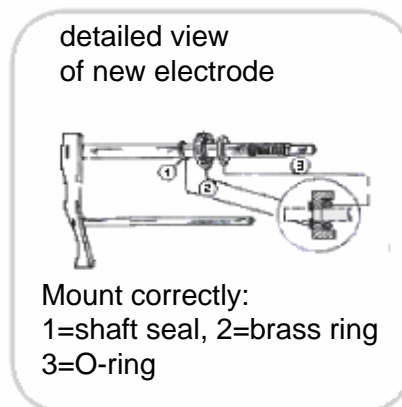
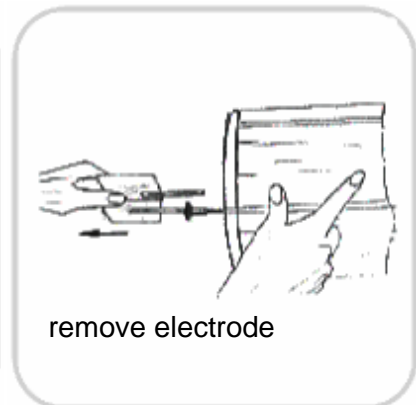

- » Remove and open cylinder, as described in Section "Removing and Cleaning Steam Cylinder."
- » Loosen knurled nuts (5) and remove electrodes (48).
- » Install new electrodes and hand tighten the nuts.
- » Use solvent-free, HygroMatik-quality o-rings (for flange, cylinder base and steam hose adapter).
- » Assemble steam cylinder and place it into cylinder
- » Connect plugs (4) directly to the electrodes (48) (with gray, red and black knurled nuts). It is not necessary to detach the knurled nuts!



Warning: The plug must be pressed down onto the electrode as far as it will go.



Note: Connect plugs to the correct electrodes. Pay attention to the color of the knurled nut.

- » Attach plug (8) to the sensor electrode. (Knurled nut (9) - gray)
- » Switch breaker back on.
- » Switch on the unit and check for leaks after 15-30 minutes of operation.

If leakage occurs, switch off power supply and follow safety instructions for work on live components.



Note: In the following cases:

- the electrodes must be frequently replaced,
- black slime collects inside the cylinder, or
- there is "lightning" in the cylinder,

the conductivity of the water is too high or it isn't decanted often enough. In this case please contact HygroMatik.

8.3 Cleaning the Blow- Down Pump

- » Remove cylinder
- » Detach e-cable from the pump.
- » Detach adapter (30) from the pump.
- » Loosen screws (44) and remove the pump from the base.
- » Open the pump (bayonet lock).
- » Remove residues from the drain hoses and pump (if necessary replace o-ring (33) or housing (34) if these components are no longer in excellent condition).
- » Reassemble the pump.
- » Moisten o-ring (31) and insert in the side connection of the base.
- » Push pump into the base and mount tightly with screws (44).
- » Moisten o-ring (31) and insert in adapter (30).
- » Fit adapter (30) over the side connection of the pump.
- » Connect e-cable to the pump.
- » Install cylinder.
- » Switch on the unit and check for leaks during operation.

If leakage occurs, switch off power supply and follow safety instructions for work on live components.

8.4 Cleaning the Water Inlet Solenoid Valve

Removal

- » Shut off water supply and loosen water installation hose connection.
- » Remove cylinder; please also see chapter „Removing and Cleaning Steam Cylinder“
- » Loosen connecting hose (21) from the base.
- » Detach e-cable from the solenoid valve.
- » Loosen solenoid valve mounting screws (28).
- » Remove solenoid valve from the borehole.
- » Remove fine mesh filter (29) from the solenoid valve, clean and replace if needed.

Installation

- » Insert fine mesh filter (29).
- » Place solenoid valve with seal in the borehole of the unit housing.
- » Attach solenoid valve tightly with screws (28).
- » Screw on water installation hose.
- » Connect e-cable to the solenoid valve.
- » Attach connecting hose (21) to the base.
- » Install cylinder.
- » Turn on the tap.
- » Switch on the unit and check for leaks during operation.

If leakage occurs, switch off power supply and follow safety instructions for work on live components.

8.5 Chekking Cable Connections and Electrode Cables

- » Make sure that no cable and plug connections are loose.



Warning: Plugs must be pressed down onto electrodes as far as they will go.

Loose cable connections cause excessive contact resistance and overheating of contact surfaces.

- » Check electrode plug isolation, replace plugs as needed.



Warning: Replace electrode plugs after removing and reinstalling them several times.

8.6 Checking Operation

Start up the unit and operate for a few minutes at maximum output if possible.

- » Check safety devices.
- » Check hose connections for possible leaks.

8.7 Dismantling

After you stop using the steam humidifier, dismantle (demolish or scrap) it by following the installation procedures in reverse order.



Warning: Dismantling of the unit is only to be attempted by qualified personnel. Electrical dismantling is only to be attempted by trained professionals.

Note the information provided in Section "Safety Notes," especially the guidelines for disposal.

9. Spare Parts

*	CompactLine Kit								Article No.	Description
	01	02	06	10	17	22	30	45		
										Bracket
	1	1	1	1					E-2101014	Steam section retaining bracket
					1	1	1		E-2107012	Steam section retaining bracket
								1	E-2107016	Steam section retaining bracket
										Steam Generation
	1								B-3216131	Steam cylinder CY1 compl. with electrodes and Hand nuts
		1							B-3204049	Steam cylinder CY2 compl. with electrodes and Hand nuts
			1						B-3216067	Steam cylinder CY4 compl. with electrodes and Hand nuts
				1					B-3204031	Steam cylinder CY8 compl. with electrodes and Hand nuts
					1				B-2204101	Steam cylinder CY17 compl. with electrodes and Hand nuts
						1			B-2204151	Steam cylinder CY17 DN40 compl. with 3 electrodes and hand nuts *
							1		B-2204111	Steam cylinder CY17 DN40 compl. with electrodes and Hand nuts
								1	B-2204105	Steam cylinder CY30 compl. with electrodes and Hand nuts
16	1								E-3216004	Top part of steam cylinder CY1 DN 20/9, empty
16		1							E-3216006	Top part of steam cylinder CY2 DN 20/9, empty
16			1						E-3216043	Top part of steam cylinder CY4 DN 20/9, empty
16				1					E-3226005	Top part of steam cylinder CY8 DN 25/12, empty
16					1				E-2206068	Top part of steam cylinder CY17 DN 25/12, empty
16						1			E-2206095	Top part of steam cylinder CY17 DN40/12, empty, 3 el.
16							1		E-2206082	Top part of steam cylinder CY17 DN 40/12, empty
16								1	E-2206069	Top part of steam cylinder CY30 DN 40/12, empty
19	1								B-3216005	Lower part of steam cylinder compl. with strainer
19		1		1					B-3216007	Lower part of steam cylinder compl. with strainer
19			1						B-3216044	Lower part of steam cylinder compl. with strainer
19					1	1	1		B-2206046	Lower part of steam cylinder compl. with strainer
19								1	B-2206071	Lower part of steam cylinder compl. with strainer
17	1								E-3216044	O-ring seal for cylinder flange, transparent cylinder
17		1		1					E-3216010	O-ring seal for cylinder flange, transparent cylinder
17			1						E-3216046	O-ring seal for cylinder flange, transparent cylinder
17					1	1	1		E-2206050	O-ring seal for cylinder flange, transparent cylinder
17								1	E-2206051	O-ring seal for cylinder flange, transparent cylinder
35	1	1	1	1					E-3216011	O-ring seal for cylinder base
35					1	1	1	1	E-2204022	O-ring seal for cylinder base
48	1	1							B-3204041	Electrodes compl. without Hand nuts, set=2pc. for CY2
48			1						B-3216061	Electrodes compl. without Hand nuts, set=3pc. for CY4
48				1					B-3204019	Electrodes compl. without Hand nuts, set=3pc. for CY8
48					1				B-2204081	Electrodes compl. without Hand nuts, set=3pc. for CY17
48						1			B-2206227	Electrodes compl. with hand nuts, set=3pc. for CY17, CY30 DN40
48							1	1	B-2204083	Electrodes compl. without Hand nuts, set=6pc. for CY17/30 DN40

*	CompactLine Kit								Article No.	Description
	1	2	6	10	17	22	30	45		
	1	1							B-3204047	Sensor electrode compl. without hand nut
			1						B-3204037	Sensor electrode compl. without hand nut
				1					B-3204027	Sensor electrode compl. without hand nut
					1	1	1	1	B-2204075	Sensor electrode compl. without hand nut
8	1	1	1	1	1	1	1	1	E-3216025	Plug-in contact with insulating hose for sensorelectrode
4	1	2	3	3					E-3216024	Plug-in contact with insulating hose for steam generating electrodes
4					3	3	6	6	E-2206059	Plug-in contact with insulating hose for steam generating electrodes
18	8	12	12	12	18	18	18	24	E-3216022	Clamp for flange of transparent cylinder
										Steam Generation
37	1	1	1	1					E-3220000	Cylinder base DN 20/12
37					1	1	1	1	E-2206086	Cylinder base DN 40/15/12
	1	1	1	1	1	1	1	1	B-3216023	Mounting set for cylinder base
12	1	1	1						E-3216020	Condensate plug DN 9
12				1	1	1	1	1	E-2204035	Condensate plug DN 12
1	1	1	1						E-3221000	Adapter DN20/25 for steam hose DN25
1				1	1				E-3221002	Adapter for steam hose DN25
1						1	1	1	E-2209004	Adapter for steam hose DN40
2	1	1	1						E-3221004	Clip for adapter DN25
3	1	1	1						E-3216011	O-ring for adapter DN20/25
3				1	1				E-3221006	O-ring for adapter DN25
3						1	1	1	E-2204022	O-ring for adapter DN40
		1							B-3216075	Maintenance Set ***
			1						B-3216077	Maintenance Set ***
				1					B-3216079	Maintenance Set ***
					1				B-2207029	Maintenance Set ***
						1			B-2207043	Maintenance Set **
							1		B-2207031	Maintenance Set ***
								1	B-2207033	Maintenance Set ***
										Water feed
	2	2	2	2	2	2	2	2	E-2304015	Hose clamp d=12 mm for waterinlet hose
21	0,6	0,6	0,6	0,6	0,6	0,6	0,6	0,6	E-2604002	Connecting hose, solenoid valve - cylinder base
25	1		1						B-2304081	Solenoid valve, servo controlled, straight type, 0,2 - 10 bar, 1,2 l/min
25		1		1					B-2304083	Solenoid valve, servo controlled, straight type, 0,2 - 10 bar, 2,5 l/min
25					1	1	1	1	B-2304085	Solenoid valve, servo controlled, straight type, 0,2 - 10 bar, 3,3 l/min
	1	1	1	1	1	1	1	1	B-2304040	Mounting set for solenoid valve
	1	1	1	1	1	1	1	1	E-2304036	Rubber seal solenoid valve - cabinet
	1	1	1	1	1	1	1	1	B-2304024	Threaded inlet fitting for solenoid valve, pipe=10mm, complete with
										Water drain
	1								B-3401027	Water-drain-hose-system (Pos.19,23,24,25,27)
		1	1	1					B-2425005	Water-drain-hose-system (Pos.19,23,24,25,27)
					1	1	1	1	B-2425009	Water-drain-hose-system (Pos.19,23,24,25,27)

*	CompactLine Kit									Article No.	Description
	1	2	6	10	17	22	30	45			
31	1	1	1	1	1	1	1	1	1	E-3220005	O-ring for adapter pump - drain hose
31	1	1	1	1	1	1	1	1	1	E-3220005	O-ring cylinder base - pump
32	1	1	1	1	1	1	1	1	1	B-2404027	Drain pump without mounting set
	1	1	1	1	1	1	1	1	1	E-2404008	Drain pump housing
	1	1	1	1	1	1	1	1	1	E-2404006	O-ring seal for drain pump
	1	1	1	1	1	1	1	1	1	B-2424014	Mounting set for drain pump
38	0,3	0,3	0,3	0,4	0,6	0,6	0,6	0,6	0,6	E-2604004	Hose EPDM (for manual draining)
	1	1	1	1	1	1	1	1	1	E-2604062	Stopper for hose E-2604010
L-Electronic											
	1	1	1	1	1	1	1	1	1	B-3504077	L-Electronic pcb compl. without mounting holder
	1	1	1	1	1	1	1	1	1	E-2525121	cover for electronic pcb
	1	1	1	1	1	1	1	1	1	B-2525122	mounting set for cover
	1	1	1	1	1	1	1	1	1	E-2525152	Terminal 2-pole
	1	1	1	1	1	1	1	1	1	E-2525154	Terminal 3-pole
	1	1	1	1	1	1	1	1	1	E-2525156	Terminal 4-pole
	1	1	1	1	1	1	1	1	1	E-2525158	Terminal 6-pole
	x	x	x	x	x	x	x	x	x	E-2502412	Control switch, double pole, middle position "0"
Accessories											
	x	x	x	x	x					E-2604012	Steam hose DN25, per m
						x	x	x		E-2604013	Steam hose DN 40, per m
	x	x	x	x	x	x	x	x		E-2604002	Condensate hose DN 12, per m
	x	x	x	x	x					E-2404004	Steam hose clamp DN 25
						x	x	x		E-2604016	Steam hose clamp DN 40
	x	x	x	x	x	x	x	x		E-2304015	Condensate hose clamp
	x	x	x	x	x	x	x	x		E-2604094	double check valve
	x	x	x	x	x					B-2604025	Steam solenoid valve 0-0,4 bar, compl. for steam hose DN 25
						x	x	x		B-2604040	Steam solenoid valve 0-0,4 bar, compl. for steam hose DN 40
	x	x	x	x	x					E-2604042	Connectors for steam distribution T-piece DN 25
						x	x	x		E-2604023	Connectors for steam distribution T-piece DN 40
	x	x	x	x	x	x	x	x		E-2604021	Connectors for condensate T-piece DN 12
				x						B-2208005	Cylinder Star
					x	x				B-2208007	Cylinder Star
							x			B-2208013	Cylinder Star
								x		B-2208009	Cylinder Star
	x	x	x	x	x					E-2604030	Elbows 90° DN 25, stainless steel
						x	x	x		E-2604036	Elbows 90° DN 40, stainless steel
		x								B-3304061	Super Flush
		x		x						B-2304063	Super Flush
					x	x	x	x		B-2304065	Super Flush

If you order any spare parts, please specify type and serial number of the unit.
* see Exploded View
** If the Super Flush System is installed, consider to order also a new nozzle (B-2304079), please.
*** Maintenance kit contains: Electrodes without hand nuts, O-rings for: adapter, cylinder base, cylinder flange, Cylinder flange clamps.

10. Fax Form - Order for spare parts

HygroMatik GmbH
Lise-Meitner-Str. 3
24558 Henstedt-Ulzburg
Tel. +4904193/895-0

Fax Form

Please copy, fill in and fax to

Fax.No. **+49(0)4193/895-31**

Order of spare parts

unit type * _____ **serial no.*** _____

commission: _____ order no.: _____

quantity	article	article no.

date of delivery _____ forwarder _____ shipment by _____

delivery address (if different from invoice address)

company stamp (delivery adress)

date/signature

* Order can only be processed if unit type and unit serial no. are filled in.

11. Exploded View

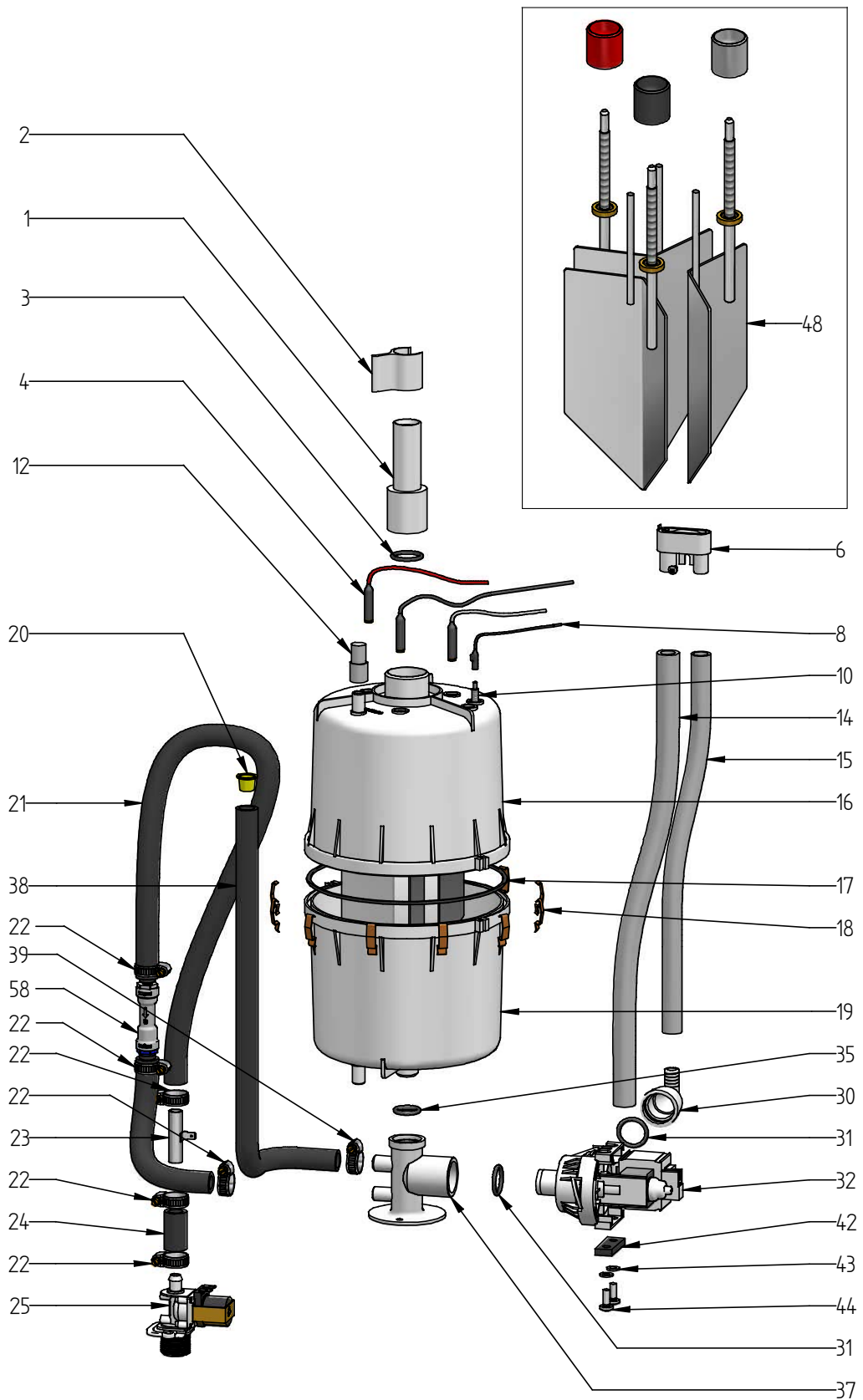

12. Technical Specification

Technical data C01Kit - C45Kit									
Type	C01 Kit	C02 Kit	C06 Kit	C10 Kit	C17 Kit	C22 Kit	C30 Kit	C45 Kit	
Steam output [kg/h]	1	2	6	10	17	22	30	45	
Power supply *	230V/1/N		400V/3/N 50-60Hz						
Power Usage [kW]	0,75	1,5	4,5	7,5	12,8	16,5	22,5	33,8	
Input [A]	3,3	6,5	6,5	10,8	18,4	23,8	32,5	48,8	
Circuit Protection [A]***	1x6	1x10	3x10	3x16	3x25	3x25	3x35	3x63	
Control	L3; optional Basic, Comfort, ComfortPlus								
Control voltage	230 V								
Steam hose connection [mm]	1x25	1x25	1x25	1x25	1x25	1x40	1x40	1x40	
Condensate hose connection [mm]	1x9	1x9	1x9	1x12	1x12	1x12	1x12	2x12	
empty weight [kg]	3,2	3,3	3,5	4,0	7,5	8,0	9,0	10,0	
operating weight [kg]	4,4	6,0	6,0	9,0	21,0	21,0	25,0	34,0	
dimensions	height [mm]	320	300	344	390	575	589	575	667
	width [mm]	252	252	252	252	328	328	328	330
	depth [mm]	175	195	175	175	254	267	254	316
Water Installation	100 x 10 ³ to 100 x 10 ⁴ pascal with 3/4" connection for external thread								
fan unit**	VG08	VG08	VG08	VG08	VG17	VG30	VG30	2xVG30	
airflow capacity [m ³ /h]	160	160	160	160	185	350	350	2x350	
* Other voltages on request. ** Not included with delivery. *** Multiply power input by 1.3 after full blow-down. Note overload capacity of automatic breakers. If necessary, select the next higher rating.									



HyGROMATIK®

Lise-Meitner-Str.3 • D-24558 Henstedt-Ulzburg
Phone +49(0)4193/ 895-0 • Fax -33
eMail hy@hygromatik.de • www.hygromatik.com
A member of the **spirax/sarco** Group